

DANISH BUSINESS TRANSACTIONS FOR THE GAS MARKET

Appendix to:
Business Scenarios for
EDI communication in the Gas Market

Version: 3
Release: 2
Dato: December, 20 2022

Indholdsfortegnelse

Change Log.....	5
1. Introduction and general principles.....	8
2. Business Transactions.....	8
2.1. BT-001: Start of Supply (UTILMD 392 / UTILMD 414).....	9
2.1.1. Initiation of the transaction.....	10
2.1.2. First dataflow: UTILMD 392.....	10
2.1.3. Second dataflow: UTILMD 414.....	11
2.1.4. Third dataflow: UTILMD 392 cancellation by Gas Supplier (optional).....	11
2.1.5. Fourth dataflow: APERAK (dependent on third dataflow).....	12
2.1.6. Fifth dataflow: UTILMD 414 cancellation by Evida (optional).....	12
2.1.7. Sixth dataflow: APERAK (dependent on fifth dataflow).....	12
2.1.8. Seventh dataflow: UTILMD 414 start of supply due to previous error (optional).....	13
2.1.9. Eighth dataflow: APERAK (dependent on seventh dataflow).....	13
2.1.10. UTILMD 392 - Dependency Matrix for Attributes.....	14
2.1.11. UTILMD 414 - Dependency Matrix for Attributes.....	15
2.1.12. APERAK - Dependency Matrix for Attributes.....	15
2.1.13. Unique Identification.....	16
2.1.14. Examples.....	16
2.2. BT-002: End of Supply - Distribution Company (UTILMD 406).....	20
2.2.1. Initiation of the transaction.....	20
2.2.2. First dataflow: UTILMD 406.....	20
2.2.3. Second dataflow: APERAK.....	21
2.2.4. UTILMD 406 - Dependency Matrix for Attributes.....	21
2.2.5. APERAK - Dependency Matrix for Attributes.....	22
2.2.6. Unique Identification.....	22
2.2.7. Examples.....	22
2.3. BT-003: End of Supply - to Distribution Company (UTILMD 432).....	24
2.3.1. Initiation of the transaction.....	24
2.3.2. First dataflow: UTILMD 432.....	25
2.3.3. Second dataflow: UTILMD 406.....	25
2.3.4. Third dataflow: UTILMD 432 cancellation (optional).....	26
2.3.5. Fourth dataflow: APERAK (dependent on third dataflow).....	26
2.3.6. Fifth dataflow: UTILMD 406 cancellation by Evida (optional).....	26
2.3.7. Sixth dataflow: APERAK (dependent on fifth dataflow).....	27
2.3.8. UTILMD 432 - Dependency Matrix for Attributes.....	28
2.3.9. UTILMD 406 answer - Dependency Matrix for Attributes.....	28
2.3.10. Unique Identification.....	29

2.3.11.	Examples.....	30
2.4.	BT-004: Master Data for Metering Point (UTILMD E07)	33
2.4.1.	Initiation of the transaction.....	33
2.4.2.	First dataflow: UTILMD E07	34
2.4.3.	Second dataflow: APERAK	34
2.4.4.	UTILMD E07 - Dependency Matrix for Attributes.....	35
2.4.5.	APERAK - Dependency Matrix for Attributes.....	36
2.4.6.	Unique Identification.....	36
2.4.7.	Examples.....	36
2.5.	BT-007: Consumption for Metering Point, profiled (MSCONS Z01)	40
2.5.1.	Initiation of the transaction.....	40
2.5.2.	First dataflow: MSCONS Z01.....	40
2.5.3.	Second dataflow: APERAK	41
2.5.4.	MSCONS Z01 - Dependency Matrix for Attributes	42
2.5.5.	APERAK - Dependency Matrix for Attributes.....	43
2.5.6.	Unique Identification.....	43
2.5.7.	Examples.....	43
2.6.	BT-008: Time series transmission (MSCONS 7)	46
2.6.1.	Initiation of the transaction.....	46
2.6.2.	First dataflow: MSCONS 7.....	47
2.6.3.	Second dataflow: APERAK	48
2.6.4.	MSCONS 7 - Dependency Matrix for Attributes	48
2.6.5.	APERAK - Dependency Matrix for Attributes.....	49
2.6.6.	Unique Identification.....	49
2.6.7.	Examples.....	49
2.7.	BT-009: Reconciliation data transmission (MSCONS 7)	58
2.7.1.	Initiation of the transaction.....	58
2.7.2.	First dataflow: MSCONS 7.....	58
2.7.3.	Second dataflow: APERAK	59
2.7.4.	MSCONS 7 - Dependency Matrix for Attributes	60
2.7.5.	APERAK - Dependency Matrix for Attributes.....	60
2.7.6.	Unique Identification.....	60
2.7.7.	Examples.....	61
2.8.	BT-010 Request for Update of Master Data (UTILMD E10).....	62
2.8.1.	Initiation of the transaction.....	62
2.8.2.	First dataflow: UTILMD E10	63
2.8.3.	Second dataflow: APERAK	63
2.8.4.	UTILMD E10 - Dependency Matrix for Attributes.....	64
2.8.5.	APERAK - Dependency Matrix for Attributes.....	64

2.8.6.	Unique Identification	65
2.8.7.	Examples.....	65
2.9.	BT-011 Meter Reading from Gas Supplier (UTILMD Z21).....	66
2.9.1.	Initiation of the transaction.....	66
2.9.2.	First dataflow: UTILMD Z21	67
2.9.3.	Second dataflow: APERAK	67
2.9.4.	UTILMD Z21 - Dependency Matrix for Attributes.....	68
2.9.5.	APERAK - Dependency Matrix for Attributes.....	68
2.9.6.	Unique Identification	69
2.9.7.	Examples.....	69

Change Log

The change log contains any changes added following the previous version or release. A change in **version** indicates significant changes to structure or syntax, whereas a new **release** contains smaller changes.

20th of December 2022:

Chapter	Transaction	Change
2.1.2	BT-001	Z18 removed as valid rejection reason from move in and secondary move in
2.1.14	BT-001	Example with change of supplier for more than one metering point corrected to not include balance responsible party
2.3.8	BT-003	Meter Reading changed to dependent. By mistake it has been marked as required.
2.8.7	BT-010	Example updated to reflect that contact address is required.

4th of August 2022:

Chapter	Transaction	Change
All		All examples updated to reflect correct IG version
2.1.4	BT-001	Removed format error code as second reason for time limit error
2.1.6	BT-001	Clarification added to point out the cancellation is for the 414-message sent earlier by Evida Removed format error code as second reason for time limit error Added E01 and Z17 as possible RFT's to the data flow
2.3.2	BT-003	Add missing description to reason Z24 in table
2.3.4	BT-003	Removed format error code as second reason for time limit error
2.3.6	BT-003	Clarification added to point out the cancellation is for the 406-message sent earlier by Evida Removed format error code as second reason for time limit error

1st of July 2022:

Chapter	Transaction	Change
All		Layout changed in entire document
2.1	BT-001	Flow diagram updated to allow for more cancellations, erroneous start of supply and secondary move in Wording slightly changed in all subsections
2.1.1	BT-001	E06 removed Z17 added New and missing validation rules added for E01/E03 Rejection reason E22 which could previously occur in multiple ways now split into E22 and Z18
2.1.2	BT-001	E06 removed Z17 added New rejection reasons added
2.1.3	BT-001	E06 removed Z17 added
2.1.4	BT-001	Added description of flow being initiated by the Gas Supplier

2.1.6	BT-001	Added new flow for cancellation of confirmation of start of supply used by Evida
2.1.7	BT-001	Added new flow for receipt of cancelling the confirmation of start of supply
2.1.8	BT-001	Added new flow for support of erroneous start of supply
2.1.9	BT-001	Added new flow for receipt of erroneous start of supply
2.1.10	BT-001	Dependency matrix extended to support cancellation by Evida E06 removed E01 dependency of meter reading changed to optional Z17 added
2.1.11	BT-001	E06 removed Z14 added Z15 added Z17 added
2.1.13	BT-001	Versioning changed
2.1.14	BT-001	Examples updated to reflect changes Example of cancellation of confirmation of start of supply added Example of start of supply due to error added
2.2	BT-002	Flow diagram updated
2.2.1	BT-002	Z08 removed Z17 added
2.2.2	BT-002	Z08 removed Z17 added
2.2.4	BT-002	Z08 removed Z17 added
2.2.6	BT-002	Versioning changed
2.2.7	BT-002	Examples updated to reflect changes
2.3	BT-003	Flow diagram updated to allow for cancellation Wording slightly changed in all subsections
2.3.1	BT-003	Z14 added Z15 added Z09 removed
2.3.2	BT-003	Added new validation rules for Z14 and Z15 Removed Z09
2.3.4	BT-003	Dataflow for cancellation added
2.3.5	BT-003	Dataflow for response to cancellation added
2.3.6	BT-003	Added new flow for cancellation of the confirmation of end of supply used by Evida
2.3.7	BT-003	Added new flow for receipt of cancellation of end of supply
2.3.8	BT-003	Dependency matrix updated to support cancellation, erroneous change of supplier and erroneous move Z09 removed
2.3.9	BT-003	Dependency matrix updated to support erroneous change of supplier, erroneous move and cancellations by Evida Z09 removed
2.3.10	BT-003	Versioning changed
2.3.11	BT-003	Examples updated to reflect changes
2.4.1	BT-004	End of delivery added as reason code Erroneous change of supplier added as reason code Erroneous move added as reason code

		Secondary move in added as reason code E06 removed as reason code Z08 removed as reason code
2.4.6	BT-004	Versioning changed
2.4.7	BT-004	Examples updated to reflect changes
2.5.6	BT-007	Versioning changed
2.5.7	BT-007	Examples updated to reflect changes
2.6.6	BT-008	Versioning changed
2.6.7	BT-008	Examples updated to reflect changes
2.7.6	BT-009	Versioning changed
2.7.7	BT-009	Examples updated to reflect changes
2.8	BT-010	New transaction added for suggestion of master data changes
2.9	BT-011	New transaction added for meter readings from Gas Supplier

Earlier:

Chapter	Transaction	Change
2.1.10.5	BT-001	Example changed. Meter reading appears in the QTY segment.
2.3.7.4	BT-003	Example changed. Meter reading appears in the QTY segment.

1. Introduction and general principles

This document is a collection of all the *Business Transactions* that are used in the *Business Scenario* document for the Danish gas market:

- *Danish Business Scenarios for EDI- communication in the Gas Market*

A *Business Transaction* in this document must be addressed in accordance with the *communication regulation*, which describes the information flow for general error handling. This includes the validation of interchange documents that have to be carried out before a more specific validation described in a *Business Transaction*.

2. Business Transactions

A *Business Transaction* is an independent element. It is independent of other EDI transactions. Business Transactions can be used as “bricks” in the Business Processes.

A Business Transaction specifies interchange of EDI documents (messages) between the IT systems of two actors. Furthermore, it specifies a part of the internal handling within an actor’s IT system. To indicate the interchanged documents and their validation *Activity Diagrams* are used.

Activity Diagrams

Interchange of messages between IT systems of two actors is illustrated in an *Activity diagram*. It shows the name of the EDI message, such as *UTILMD 392* and the actors this message is interchanged between, in this case a *Gas Supplier* and a *Distribution Company*. Most of the messages are *UTILMD* but also *MSCONS* and *APERAK* are used. In the message a code is used to state a reason for transaction such as *E03* for *change of supplier*.

Validation tables

Recipient of the message validates the message and afterwards, undertakes a specific validation in accordance with a *Validation Table*, which is documented in a *Business Transaction*. After the received message is processed, an EDI message is sent back as an answer.

Both the initiating message and the answer message contain a list of *Attributes*, which are included in the message as referred to as a *Dependency Matrix*.

Dependency Matrix for Attributes

A *Dependency Matrix* exists for all the messages a *Business Transaction* contains. The *Dependency Matrix* shows the dependency of the *Attributes* in a message. An *Attribute* can be “required”, “dependent” or “not used” in a message.

The first column in a *Dependency Matrix* named *Attribute* refers to the *Attributes* that are specified in a *Data Model* in the individual Danish EDI Message Implementation Guides.

The second column in a *Dependency Matrix* named RFT Gas refers to the *Reason for transaction*. *Reason for transaction* (E03, E05 etc.) refers to the name of each message. In these columns it is specified, whether an attribute is *Required (R)*, *Dependent (D)* or *Not used (X)* in a message. The *Attribute Request for acknowledgement* is always required. It can have value *NA* (*No acknowledgement needed*) or *AB* (*Message acknowledgement is required - APERAK*).

2.1. BT-001: Start of Supply (UTILMD 392 / UTILMD 414)

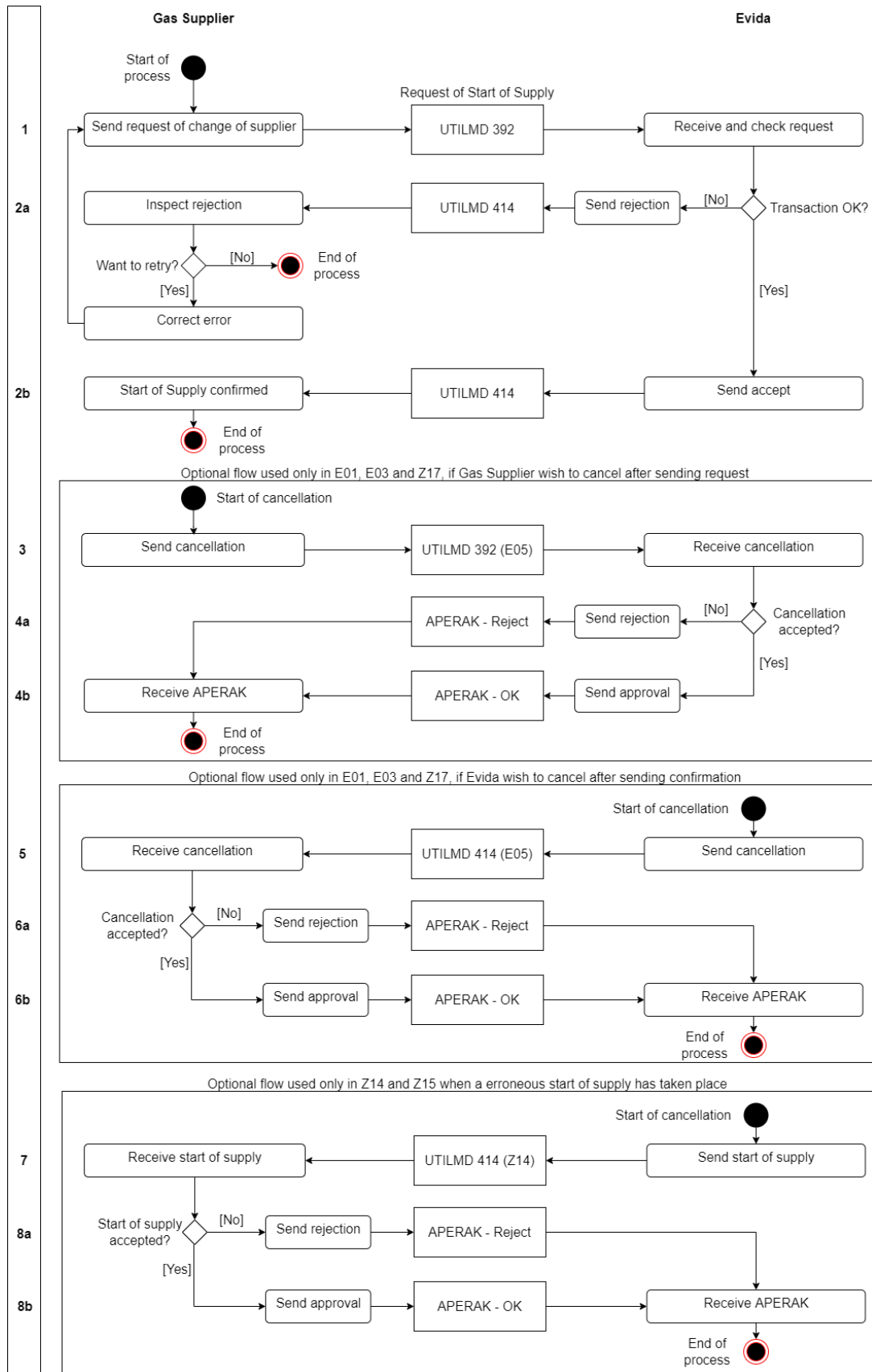

Figure 1: BT-001: Start of Supply (UTILMD 392/UTILMD 414)

Business Transaction, BT-001, is used by the *Gas Supplier* to send a *request for start of supply* to Evida.

2.1.1. Initiation of the transaction

The transaction is initiated by a UTILMD message with a document name code 392 (*Request of start of supply*). The message can hold one or more transactions that all use the same *Reason For Transaction (RFT)*. The values can be:

- E01 (*Move*)
- E03 (*Change of supplier*)
- Z17 (*Secondary move in*)

2.1.2. First dataflow: UTILMD 392

The message in the first dataflow is sent with data as referred to in the *dependency matrix* (see section 2.1.10).

Receipt

On receipt of the message the validation is carried out in accordance with *EDI-communication (Regulation F)*.

Afterwards, each transaction is verified in accordance with the business rules, which are documented in Table 1.

RFT	Validation	Reason for answer
E03	The <i>Message Sender</i> (Gas Supplier) must not be equal to present <i>Gas Supplier</i> for the <i>Metering point</i>	E59 (Already existing relation (Rejection))
E01 E03 Z17	The <i>Metering point</i> must be administrated by Evida	E10 (Installation address or metering point not identifiable)
E03	A move in is registered prior to the requested date	Z18 (Metering point blocked for switching)
E01 E03 Z17	The <i>Gas Supplier</i> must be approved (authorised) at <i>Contract Start Date</i> .	E16 (Unauthorised supplier)
E01 E03 Z17	The Change of Supplier is already done for the switch date	E22 (Metering point blocked for switching)
E01 E03 Z17	The Metering Point has been discontinued on the requested date	Z12 (Discontinued Metering Point)
E03	The message must be received within the official time limit for change of supplier	E17 (Requested switch date not within time limits)
E01 Z17	The message must be received within the time limit for move	E17 (Requested switch date not within time limits)

Table 1: BT-001: Validation of first dataflow: UTILMD 392

If all metering points cannot be validated before sending the response, they must be validated during the cancellation period. This is, however, only possible when the value of RFT is E03 (change of supplier).

2.1.3. Second dataflow: UTILMD 414

For all transactions received in the first dataflow an answer has to be given in one or more *UTILMD 414* messages. If a transaction fulfils all conditions in the validation table for the first dataflow, it must be approved by setting the *status for answer* to “39” (*approved*). If not, the *status for answer* is set to “41” (*rejected*) and the *Reason for answer* as shown in the validation table shall be used. For the remaining data, the message is sent with data as referred to in the dependency matrix (see section 2.1.11). An *APERAK* is not requested as *UTILMD 414* is used as a receipt for *UTILMD 392*.

Receipt

On receipt of the message the validation is carried out in accordance with *EDI-communication (Regulation F)*.

Afterwards, each transaction is tested in accordance with the business rules, which are documented in Table 2.

RFT	Validation	Error code
E01 E03 Z17	The <i>Contract start date</i> must be as stated in the first dataflow	42 (Error in content of a data element)
E01 E03 Z17	The <i>Gas Supplier</i> must be <i>Sender</i> of the <i>Request of start of supply</i>	42 (Error in content of a data element)

Table 2 BT-001: Validation of second dataflow: UTILMD 414

The *Gas Supplier* receives *UTILMD 414* and examines the message for rejected metering points. Errors in rejected metering points must be corrected and resent in a new message.

In case of verification failure, a negative *APERAK* is sent in accordance with *EDI-communication*. Please note that it is not allowed to send a positive *APERAK* for transactions that have passed the verification.

The *Gas Supplier* must verify the confirmed transactions manually to ensure that the switches are taking place for the correct customers. If this is not the case, then the optional third (and fourth) dataflow can be applied to cancel the change (when RFT is E03 (change of supplier)).

2.1.4. Third dataflow: UTILMD 392 cancellation by Gas Supplier (optional)

This optional data flow can only be used when the Business Transaction is initiated by a *RFT* of *E03 (Change of supplier)*.

A *Gas Supplier* can cancel an already sent *request for start of supply* by sending the transaction again with a new *transaction id* and *E05 (Cancellation of transaction)* as *RFT* and the *transaction id* of the transactions to be cancelled as *Reference to transaction id*. In that case the *Gas Supplier* must request an acknowledgement (*APERAK*).

Receipt

On receipt of the message the validation is carried out in accordance with *EDI-communication*.

Afterwards, each transaction is verified in accordance with the business rules, which are documented in Table 3.

RFT	Validation	Error code
E05	The <i>Reference to Transaction id</i> must be equal to the <i>Transaction id</i> that <i>Message Sender</i> has sent before	42 (Error in content of a data element)
E05	Time of reception must be within the official time limit for cancellation by the <i>Gas Supplier</i>	51 (The message was received too late)

Table 3 BT-001: Validation of third dataflow: UTILMD 392

2.1.5. Fourth dataflow: APERAK (dependent on third dataflow)

If a transaction fulfils all the conditions in the validation tables, it must be approved. This is done by sending a positive *APERAK* with *message function* "34" (*Accepted with amendment*), the *error code* "100" (*The object is approved*) and "Godkendt/Approved" as *error description*. The transaction reference shall indicate the *Transaction ID*.

In case of verification failure, the transaction is rejected by a negative *APERAK* with the *message function* "34" (*Accepted with amendment*) and the *error code* value as indicated in the validation table. The name of the *attribute* that is the cause for failure must be stated in both Danish and English in the error description. The transaction reference shall indicate the *Transaction ID*.

Receipt

On receipt of the message the validation is carried out in accordance with *EDI-communication*.

Afterwards, the application is not allowed to reject the transactions.

2.1.6. Fifth dataflow: UTILMD 414 cancellation by Evida (optional)

This optional data flow can be used when the Business Transaction is initiated by a *RFT* of *E01 (Move)*, *E03 (Change of Supplier)* or *Z17 (Secondary move in)*.

Evida can cancel an already sent *confirmation of start of supply* by sending the transaction again with a new *transaction id* and *E05 (Cancellation of transaction)* as *RFT* and the *transaction id* of the transactions to be cancelled as *Reference to transaction id*. The transactions will be from the original UTILMD 414 sent by Evida. In that case Evida must request an acknowledgement (*APERAK*). Upon receipt this cancels the entire ongoing process.

Receipt

On receipt of the message the validation is carried out in accordance with *EDI-communication*.

Afterwards, each transaction is verified in accordance with the business rules, which are documented in the following table.

RFT	Validation	Error code
E05	The <i>Reference to Transaction id</i> must be equal to the <i>Transaction id</i> that <i>Message Sender</i> has sent before	42 (Error in content of a data element)
E05	Time of reception must be within the official time limit for cancellation by Evida	51 (The message was received too late)

Table 4 BT-001: Validation of fifth dataflow: UTILMD 414

2.1.7. Sixth dataflow: APERAK (dependent on fifth dataflow)

If a transaction fulfils all the conditions in the validation tables, it must be approved. This is done by sending a positive *APERAK* with *message function* "34" (*Accepted with amendment*), the *error code* "100" (*The object is approved*) and "Godkendt/Approved" as *error description*. The transaction reference shall indicate the *Transaction ID*.

In case of verification failure, the transaction is rejected by a negative *APERAK* with the *message function* "34" (*Accepted with amendment*) and the *error code* value as indicated in the validation table. The name of the *attribute* that is the cause for failure must be stated in both Danish and English in the error description. The transaction reference shall indicate the *Transaction ID*.

Receipt

On receipt of the message the validation is carried out in accordance with *EDI-communication*.

Afterwards, the application is not allowed to reject the transactions.

2.1.8. Seventh dataflow: UTILMD 414 start of supply due to previous error (optional)

This optional data flow can only be used when the Business Transaction is initiated by a RFT of Z14 (*erroneous change of supplier*) or Z15 (*erroneous move*).

Evida can notify the previous Gas Supplier to resume the delivery of gas on a date where they previously lost the delivery. This is done by sending a confirmation of start of supply to the original Gas Supplier with the reason code Z14 (*erroneous change of supplier*) or Z15 (*erroneous move*).

Receipt

On receipt of the message the validation is carried out in accordance with *EDI-communication*.

Afterwards, each transaction is verified in accordance with the business rules, which are documented in the following table. Note that the original Gas Supplier is required to accept the message if it is syntactically correct.

RFT	Validation	Error code
Z14 Z15	The message is not syntactically correct	42 (Error in content of a data element)

Table 5 BT-001: Validation of seventh dataflow: UTILMD 414

2.1.9. Eighth dataflow: APERAK (dependent on seventh dataflow)

If a transaction fulfils all the conditions in the validation tables, it must be approved. This is done by sending a positive APERAK with *message function "34" (Accepted with amendment)*, the *error code "100" (The object is approved)* and "*Godkendt/Approved*" as *error description*. The transaction reference shall indicate the *Transaction ID*.

In case of verification failure, the transaction is rejected by a negative APERAK with the *message function "34" (Accepted with amendment)* and the *error code* value as indicated in the validation table. The name of the *attribute* that is the cause for failure must be stated in both Danish and English in the error description. The transaction reference shall indicate the *Transaction ID*.

Receipt

On receipt of the message the validation is carried out in accordance with *EDI-communication*.

Afterwards, the application is not allowed to reject the transactions.

2.1.10. UTILMD 392 - Dependency Matrix for Attributes

Attributes	RFT Dependency			
	E01	E03	E05	Z17
IG version	R			
BT combined ID				
Market				
Message date				
Message function				
Message id				
Message name				
Message recipient				
Message sender				
Request for acknowledgement				
Time zone (UTC+0)				
Metering point id				
Reason for transaction				
Transaction id				
Reference to transaction	X	X	R	X
Consumer party name	R	X	X	R
Consumer party contact address	R	X	X	R
Contract start date	R			
Meter reading	D*	X	X	D*

Table 6 BT-001: Dependency Matrix for attributes: UTILMD 392

R= Required, D= Dependent, X= not used

* Meter reading is only filled if its available, otherwise, skip the segment

2.1.11. UTILMD 414 - Dependency Matrix for Attributes

Attributes	RFT Dependency					
	E01	E03	Z17	E05	Z14	Z15
IG version						
BT combined ID						
Market						
Message date						
Message function						
Message id						
Message name						
Message recipient		R		R		R
Message sender						
Request for acknowledgement						
Time zone (UTC+0)						
Metering point id						
Reason for transaction						
Transaction id						
Reference to transaction					X	X
Status for answer				X	X	X
Reason for answer		D*		X	X	X
Consumer Party name	X	D**	X	X	R	R
Contract start date		D**		R	R	R

Table 7 BT-001: Dependency matrix for attributes: UTILMD 414

R= Required, D= Dependent, X= not used

* Not used when Status for answer is "39" (approved).

** Not used when Status for answer is "41" (rejected).

2.1.12. APERAK - Dependency Matrix for Attributes

Attributes	Dependency
IG version	R
BT combined ID	
Message date	
Message function	
Message recipient	
Message sender	
Reference to message	
Application error code	
Error description	
Transaction reference	

Table 8 BT-001: Dependency matrix for attributes: APERAK

R= Required

2.1.13. Unique Identification

BT ID	DK-BT-001
BT navn	Start of Supply
BT version	5
BT combined ID	DK-BT-001-005
BPI	DK-CUS
EDI Messages:	
Message ID	UTILMD 392
Message name	Request of Start of Supply
Message IG version	5.0 B
DK IG version	3
Message ID	UTILMD 414
Message name	Confirmation of Start of Supply
Message IG version	5.0 B
DK IG version	3
Message ID	APERAK
Message name	Application error and acknowledgement message
Message IG version	2.4 B
DK IG version	3

2.1.14. Examples

UTILMD 392-E03 (Change of Supplier for one metering point)

```

UNA:+. ? '
UNB+UNOC:3+5799999933318:14+5799999911118:14+031001:1400+UNIKT001++DK-
CUS+++DK '
UNH+1+UTILMD:D:02B:UN:E5DK03+DK-BT-001-005 '
BGM+392+222+9+NA '
DTM+137:200310011200:203 '
DTM+735: ?+0000:406 '
MKS+27+E01::260 '
NAD+MS+5799999933318::9 '
NAD+MR+5799999911118::9 '
IDE+24+10250907 '
DTM+92:200312010500:203 '
STS+7++E03::260 '
LOC+172+571515199988888819::9 '
UNT+12+1 '
UNZ+1+UNIKT001 '

```

UTILMD 392-E03 (Change of Supplier for more than one metering point)

```

UNA:+. ? '
UNB+UNOC:3+5799999933318:14+5799999911118:14+031001:1400+UNIKT002++DK-
CUS+++DK '
UNH+1+UTILMD:D:02B:UN:E5DK03+DK-BT-001-005 '
BGM+392+MES002+9+NA '
DTM+137:200310011200:203 '
DTM+735: ?+0000:406 '
MKS+27+E01::260 '
NAD+MS+5799999933318::9 '

```

NAD+MR+5799999911118::9'
IDE+24+TrID02'
DTM+92:200311300500:203'
STS+7++E03::260'
LOC+172+571515199988888819::9'
IDE+24+TrID03'
DTM+92:200311300500:203'
STS+7++E03::260'
LOC+172+571515199988888826::9'
IDE+24+TrID04'
DTM+92:200311300500:203'
STS+7++E03::260'
LOC+172+571515199988888833::9'
UNT+21+1'
UNZ+1+UNIKT002'

UTILMD 392-E05 (Cancellation)

UNA:+.?'
UNB+UNOC:3+5799999933318:14+5799999911118:14+031001:1400+UNIKT003++DK-
CUS+++DK'
UNH+1+UTILMD:D:02B:UN:E5DK03+DK-BT-001-005'
BGM+392+MES003+9+AB'
DTM+137:200310011200:203'
DTM+735:?+0000:406'
MKS+27+E01::260'
NAD+MR+5799999911118::9'
NAD+MS+5799999933318::9'
IDE+24+TrID05'
DTM+92:200312010500:203'
STS+7++E05::260'
LOC+172+571515199988888819::9'
RFF+TN:TrID01'
UNT+13+1'
UNZ+1+UNIKT003'

UTILMD 414-E03 (Approval of Change of Supplier for one metering point)

UNA:+.?'
UNB+UNOC:3+5791111333334:14+5790000333318:14+031001:1415+UNIKT011++DK-
CUS+++DK'
UNH+1+UTILMD:D:02B:UN:E5DK03+DK-BT-001-005'
BGM+414+222+9+NA'
DTM+137:200303271352:203'
DTM+735:?+0000:406'
MKS+27+E01::260'
NAD+MR+5791111333334::9'
NAD+MS+5790000333318::9'
IDE+24+24400111114'
DTM+92:200401010500:203'
STS+7++E03::260'
STS+E01::260+39'
LOC+172+571515199988888819::9'
RFF+TN:10250907'
NAD+UD+++John Jensen'
UNT+15+1'
UNZ+1+UNIKT011'

UTILMD 414-E05 (Cancellation of approval of Change of Supplier)

UNA:+. ? '

UNB+UNOC:3+5791111333334:14+5790000333318:14+031001:1415+UNIKT038++DK-

CUS+++DK '

UNH+1+UTILMD:D:02B:UN:E5DK03+DK-BT-001-005 '

BGM+414+222+9+NA '

DTM+137:200303271352:203 '

DTM+735:?:+0000:406 '

MKS+27+E01:::260 '

NAD+MR+5791111333334:::9 '

NAD+MS+5790000333318:::9 '

IDE+24+24400111118 '

DTM+92:200401010500:203 '

STS+7++E05:::260 '

LOC+172+571515199988888819:::9 '

RFF+TN:24400111114 '

UNT+13+1 '

UNZ+1+UNIKT038 '

UTILMD 392-E01 (Move, company)

UNA:+. ? '

UNB+UNOC:3+5790000333318:14+5791111333334:14+031001:1400+UNIKT001++DK-

CUS+++DK '

UNH+1+UTILMD:D:02B:UN:E5DK03+DK-BT-001-005 '

BGM+392+222+9+NA '

DTM+137:200303271352:203 '

DTM+735:?:+0000:406 '

MKS+27+E01:::260 '

NAD+MR+5790000333318:::9 '

NAD+MS+5791111333334:::9 '

IDE+24+10250907 '

DTM+92:200401010500:203 '

STS+7++E01:::260 '

LOC+172+571515199988888819:::9 '

SEQ++1 '

QTY+220:912569:MTQ '

NAD+UD+12345678++John Jensen+Jensensvej:::5+Fredericia++7000+DK '

UNT+15+1 '

UNZ+1+UNIKT001 '

UTILMD 414-E01 (Approval of Move for one metering point)

UNA:+. ? '

UNB+UNOC:3+5799999911118:14+5799999933318:14+031001:1415+UNIKT018++DK-

CUS+++DK '

UNH+1+UTILMD:D:02B:UN:E5DK03+DK-BT-001-005 '

BGM+414+MES011+9+NA '

DTM+137:200310011215:203 '

DTM+735:?:+0000:406 '

MKS+27+E01:::260 '

NAD+MS+5799999911118:::9 '

NAD+MR+5799999933318:::9 '

IDE+24+TrID18 '

DTM+92:200312010500:203 '

STS+7++E03:::260 '

STS+E01:::260+39 '

LOC+172+571515199988888819:::9 '

RFF+TN:TrID04'
UNT+14+1
UNZ+1+UNIKT018'

UTILMD 414-Z14 (Start of supply due to error)

UNA:+.?'
UNB+UNOC:3+5791111333334:14+5790000333318:14+031001:1415+UNIKT029++DK-
CUS+++DK'
UNH+1+UTILMD:D:02B:UN:E5DK03+DK-BT-001-005'
BGM+414+222+9+NA'
DTM+137:200402011352:203'
DTM+735:?+0000:406'
MKS+27+E01::260'
NAD+MR+5791111333334::9'
NAD+MS+5790000333318::9'
IDE+24+24400111114'
DTM+92:200401010500:203'
DTM+157:200402010500:203'
STS+7++Z14::260'
LOC+172+571515199988888819::9'
RFF+TN:10250907'
NAD+UD+++John Jensen'
UNT+15+1'
UNZ+1+UNIKT029'

2.2. BT-002: End of Supply - Distribution Company (UTILMD 406)

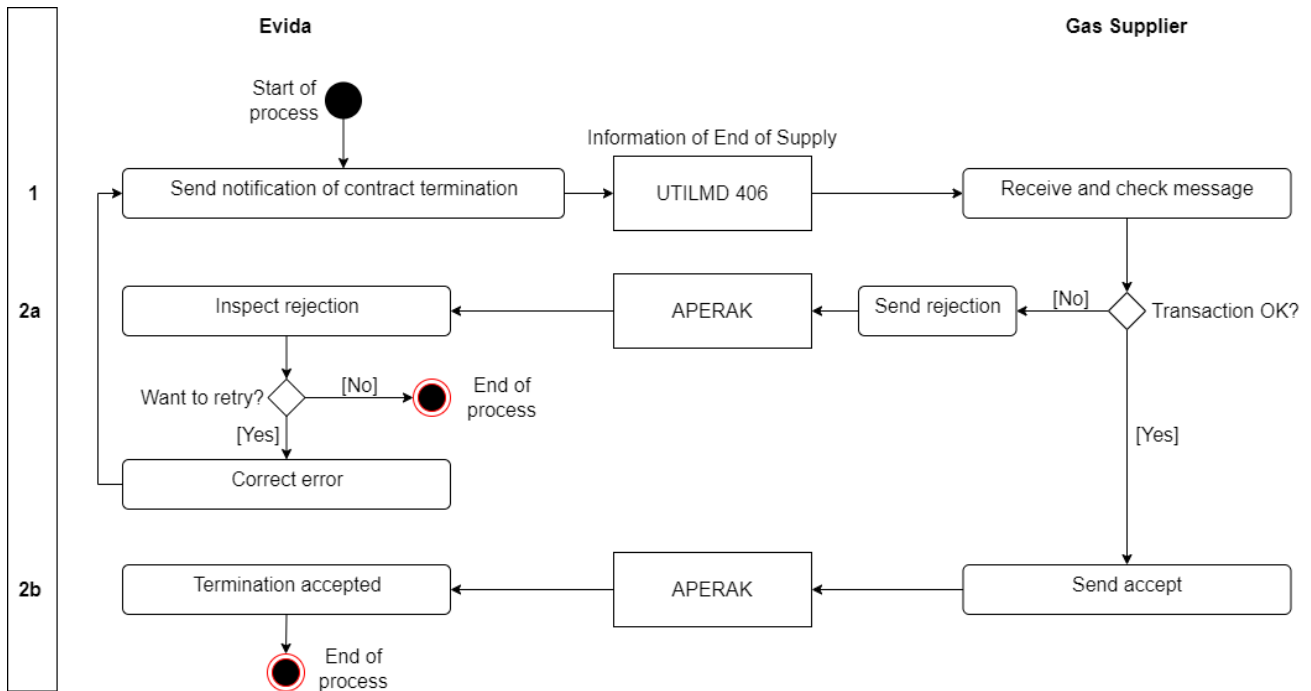

Figure 2: BT-002: End of Supply - from Distribution Company (UTILMD 406).

Business Transaction BT-002 is used by Evida to inform the Gas Supplier about the end of supply. The Gas Supplier must end the supply at the Contract stop date.

2.2.1. Initiation of the transaction

The transaction is initiated by a *UTILMD* message with a document name code *406* (*Information of end of supply*). The message can hold one or more transactions that all use the same *Reason for Transaction (RFT)*. The values can be:

- *E01* (Move)
- *E03* (Change of supplier)
- *Z10* (Termination of metering point)
- *Z17* (Secondary move in)

2.2.2. First dataflow: UTILMD 406

The message is sent with data as referred to in the dependency matrix (*see section 2.2.4*).

Receipt

On receipt of the message the validation is carried out in accordance with *EDI-communication (Regulation F)*.

Afterwards, each transaction is verified in accordance with the business rules, which are documented in Table 9.

RFT	Validation	Error code
E01 E03 Z10 Z17	The <i>Message Recipient</i> must be the present Gas Supplier to the <i>Metering point</i>	42 (Error in content of a data element)
E01 E03 Z10 Z17	Time of receipt of the message must be within the official time limit.	42 (Error in content of a data element)

Table 9: BT-002: Validation of first dataflow: UTILMD 406

2.2.3. Second dataflow: APERAK

If a transaction fulfils all the conditions in Table 9, it must be approved. This is done by sending a positive APERAK with *message function "34" (Accepted with amendment)*, the *error code "100" (The object is approved)* and "Godkendt/Approved" as *error description*. The transaction reference shall indicate the *Transaction ID*.

In case of verification failure, the transaction is rejected by a negative APERAK with *message function "34" (Accepted with amendment)* and the *error code* value indicated in the validation table. The name of the attribute that is the cause for failure must be stated in both Danish and English in the *error description*. The transaction reference shall indicate the *Transaction ID*.

Receipt

On receipt of the message the validation is carried out in accordance with *EDI-communication (Regulation F)*.

Afterwards, the application is not allowed to reject the transactions.

2.2.4. UTILMD 406 - Dependency Matrix for Attributes

Attributes	RFT dependency			
	E01	E03	Z10	Z17
IG version				
BT Combined ID				
Market				
Message date				
Message function				
Message id				
Message name				
Message recipient		R		
Message sender				
Request for acknowledgement				
Time zone (UTC+0)				
Metering point id				
Reason for transaction				
Transaction id				
Contract stop date				

Table 10 BT-002: Dependency matrix for attributes: UTILMD 406

R= Required

2.2.5. APERAK - Dependency Matrix for Attributes

Attributes	Dependency
IG version	R
BT combined ID	
Message date	
Message function	
Message recipient	
Message sender	
Reference to message	
Application error code	
Error description	
Transaction reference	

Table 11 BT-002: Dependency matrix for attributes: APERAK

R= Required

2.2.6. Unique Identification

BT ID	DK-BT-002
BT navn	End of Supply – from MPA
BT version	5
BT combined ID	DK-BT-002-005
BPI	DK-CUS
EDI Messages:	
Message ID	UTILMD 406
Message name	Information of End of Supply
Message IG version	5.0 B
DK IG version	3
Message ID	APERAK
Message name	Application error and acknowledgement message
Message IG version	2.4 B
DK IG version	3

2.2.7. Examples

UTILMD 406-E03: End of Supply from Distribution Company for one metering point

```

UNA:+. ? '
UNB+UNOC:3+5799999933318:14+5799999911118:14+031007:1400+UNIKT021++DK-
CUS+++DK '
UNH+1+UTILMD:D:02B:UN:E5DK03+DK-BT-002-005 '
BGM+406+MES021+9+AB '
DTM+137:200310071200:203 '
DTM+735:?:+0000:406 '
MKS+27+E01:::260 '
NAD+MS+5799999933318:::9 '
NAD+MR+5799999911118:::9 '
IDE+24+TrID21 '
DTM+93:200310310500:203 '
STS+7++E03:::260 '
LOC+172+571515199988888819:::9 '
UNT+12+1 '

```

UNZ+1+UNIKT021'

UTILMD 406-E03 (End of Supply from Distribution Company DISTRIBUTION COMPANY for more than one metering point)

UNA:+.?'
UNB+UNOC:3+5799999933318:14+5799999911118:14+031007:1400+UNIKT022++DK-
CUS+++DK'
UNH+1+UTILMD:D:02B:UN:E5DK03+DK-BT-002-005'
BGM+406+MES022+9+AB'
DTM+137:200310071200:203'
DTM+735:?+0000:406'
MKS+27+E01::260'
NAD+MS+5799999933318::9'
NAD+MR+5799999911118::9'
IDE+24+TrID22'
DTM+93:200310310500:203'
STS+7++E03::260'
LOC+172+571515199988888819::9'
IDE+24+TrID23'
DTM+93:200310310500:203'
STS+7++E03::260'
LOC+172+571515199988888826::9'
UNT+16+1'
UNZ+1+UNIKT022'

Positive APERAK (answer to UTILMD 406-E03)

UNA:+.?'
UNB+UNOC:3+5799999933318:14+5799999911118:14+031001:1432+UNIKT085++DK-
CUS+++DK'
UNH+1+APERAK:D:96A:UN:E2DK03+DK-BT-002-005'
BGM+++34'
DTM+137:200310011432:203'
RFF+ACW:MES021'
NAD+FR+5799999933318::9'
NAD+DO+5799999911118::9'
ERC+100::ZZZ'
FTX+AAO+++Godkendt / Approved'
RFF+LI:TrID21'
UNT+10+1'
UNZ+1+UNIKT085'

Positive APERAK (answer to UTILMD 406-E03)

UNA:+.?'
UNB+UNOC:3+5799999933318:14+5799999911118:14+031001:1432+UNIKT086++DK-
CUS+++DK'
UNH+1+APERAK:D:96A:UN:E2DK03+DK-BT-002-005'
BGM+++34'
DTM+137:200310011432:203'
RFF+ACW:MES021'
NAD+FR+5799999933318::9'
NAD+DO+5799999911118::9'
ERC+42::ZZZ'
FTX+AAO+++Målepunkt ikke kendt / Meteringpoint not recognised,
1234567890123456:78'
RFF+LI:TrID21'
UNT+10+1'
UNZ+1+UNIKT086'

2.3. BT-003: End of Supply - to Distribution Company (UTILMD 432)

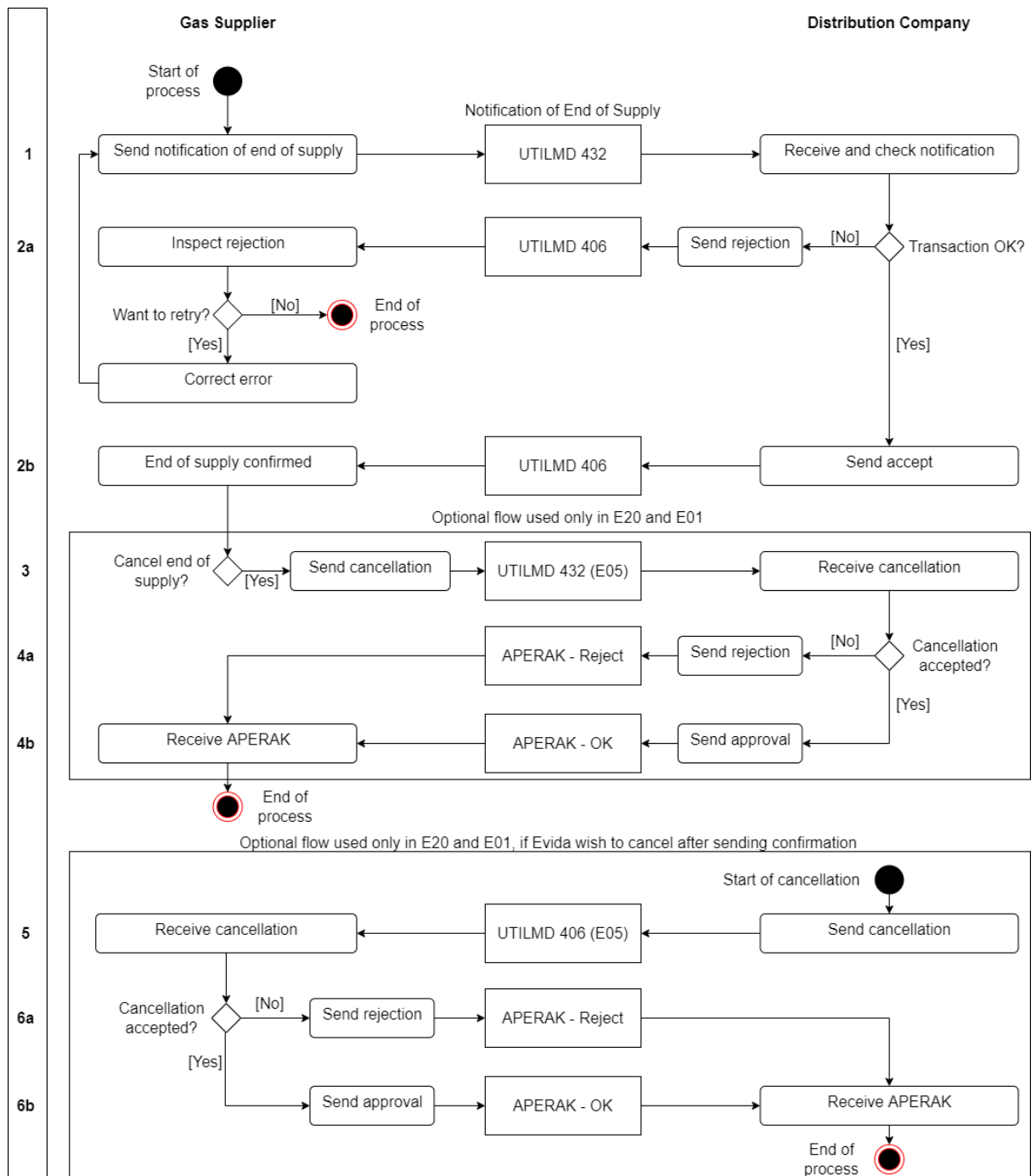

Figure 3: BT-003: End of Supply – to Distribution Company (UTILMD 432)

Business Transaction BT-003 is used by the *Gas Supplier* to inform the *Distribution Company* about the end of supply. The *Gas Supplier* wish to end the supply at the *Contract stop date*. The actual date is determined by the *Distribution Company*.

2.3.1. Initiation of the transaction

The transaction is initiated by a *UTILMD* message with a document name code 432 (Notification of end of supply). The message can hold one or more transactions that all use the same *Reason For Transaction (RFT)*. The value can be:

- E01 (Move)
- E20 (End of supply)
- Z14 (Erroneous change of supplier)
- Z15 (Erroneous move)

2.3.2. First dataflow: UTILMD 432

The message is sent with data as referred to in the dependency matrix (see section 2.3.8).

Receipt

On receipt of the message the validation is carried out in accordance with *EDI-communication (Regulation F)*.

Afterwards, each transaction is verified in accordance with the business rules, which are documented in Table 12.

RFT	Validation	Reason for answer
E01 E20 Z14 Z15	The <i>Message Sender (Gas Supplier)</i> must be equal to the present <i>Gas Supplier</i> for the <i>Metering point</i>	E16 (Unauthorised supplier)
E01 E20 Z14 Z15	The <i>Metering point</i> must be administrated by the <i>Distribution Company</i> .	E10 (Installation address or metering point not identifiable)
E01 E20 Z14 Z15	The message must be received within the official time limit	E17 (Requested switch date not within time limits)
Z14 Z15	The change is not the latest on the metering point	Z19 (Not the latest process)
Z14 Z15	The specified date does not match an existing process	Z20 (No process on requested date)
E01 E20 Z14 Z15	The <i>Metering Point</i> has been discontinued on the requested date	Z12 (Discontinued Metering Point)
Z14 Z15	The previous <i>Gas Supplier</i> can no longer receive the <i>Metering Point</i>	Z13 (Previous Gas Supplier invalid)
E01	The customers new address is missing	Z24 (New address missing)

Table 12 BT-003: Validation of first dataflow: UTILMD 432

2.3.3. Second dataflow: UTILMD 406

For all transactions received in the first dataflow, an answer must be given in one or more *UTILMD 406* messages. If a transaction fulfils all conditions in the validation table for the first dataflow, it must be approved by setting status for answer to "39" (*approved*). If not, the status for answer is set to "41" (*rejected*) and *Reason for answer* shown in Table 12 must be used. For the remaining data, the message is sent with data as referred to in the dependency matrix (see section 2.3.9).

Receipt

On receipt of the message the validation is carried out in accordance with *EDI-communication (Regulation F)*.

If a rejection is received from the *Distribution Company* the *Gas Supplier* can correct the error and send a new *UTILMD 432* with a new *Transaction id*. Alternatively, the *Gas Supplier* can contact the *Distribution Company* to solve the problem.

Afterwards, the application is not allowed to reject the transactions.

2.3.4. Third dataflow: UTILMD 432 cancellation (optional)

This optional data flow can only be used when the Business Transaction is initiated by a RFT of E20 (End of Supply) or E01 (Move).

A Gas Supplier can cancel an already sent end of supply by sending the transaction again with a new transaction id and E05 (Cancellation of transaction) as RFT and the transaction id of the transactions to be cancelled as Reference to transaction id. In that case the Gas Supplier must request an acknowledgement (APERAK).

Receipt

On receipt of the message the validation is carried out in accordance with EDI-communication (Regulation F).

Afterwards, each transaction is verified in accordance with the business rules, which are documented in [Table 13 - Validation of cancellation of end of supply](#)

RFT	Validation	Error code
E05	The Reference to Transaction id must be equal to the Transaction id that Message Sender has sent before	42 (Error in content of a data element)
E05	Time of reception must be within the official time limit for cancellation	51 (The message was received too late)

Table 13 - Validation of cancellation of end of supply

2.3.5. Fourth dataflow: APERAK (dependent on third dataflow)

If a transaction fulfils all the conditions in the validation tables, it must be approved. This is done by sending a positive APERAK with message function "34" (Accepted with amendment), the error code "100" (The object is approved) and "Godkendt/Approved" as error description. The transaction reference shall indicate the Transaction ID.

In case of verification failure, the transaction is rejected by a negative APERAK with the message function "34" (Accepted with amendment) and the error code value as indicated in the validation table. The name of the attribute that is the cause for failure must be stated in both Danish and English in the error description. The transaction reference shall indicate the Transaction ID.

Receipt

On receipt of the message the validation is carried out in accordance with EDI-communication (Regulation F).

Afterwards, the application is not allowed to reject the transactions.

2.3.6. Fifth dataflow: UTILMD 406 cancellation by Evida (optional)

This optional data flow can only be used when the Business Transaction is initiated by a RFT of E20 (End of Supply) or E01 (Move).

Evida can cancel an already sent confirmation of end of supply by sending the transaction again with a new transaction id and E05 (Cancellation of transaction) as RFT and the transaction id of the transactions to be cancelled as Reference to transaction id. The transactions will be from the original UTILMD 406 sent by Evida. In that case Evida must request an acknowledgement (APERAK). Upon receipt this cancels the entire ongoing process.

Receipt

On receipt of the message the validation is carried out in accordance with *EDI-communication*.

Afterwards, each transaction is verified in accordance with the business rules, which are documented in the following table.

RFT	Validation	Error code
E05	The <i>Reference to Transaction id</i> must be equal to the <i>Transaction id</i> that <i>Message Sender</i> has sent before	42 (Error in content of a data element)
E05	Time of reception must be within the official time limit for cancellation by Evida	51 (The message was received too late)

Table 14 BT-003: Validation of fifth dataflow: UTILMD 406

2.3.7. Sixth dataflow: APERAK (dependent on fifth dataflow)

If a transaction fulfils all the conditions in the validation tables, it must be approved. This is done by sending a positive *APERAK* with *message function* "34" (*Accepted with amendment*), the *error code* "100" (*The object is approved*) and "Godkendt/Approved" as *error description*. The transaction reference shall indicate the *Transaction ID*.

In case of verification failure, the transaction is rejected by a negative *APERAK* with the *message function* "34" (*Accepted with amendment*) and the *error code* value as indicated in the validation table. The name of the *attribute* that is the cause for failure must be stated in both Danish and English in the error description. The transaction reference shall indicate the *Transaction ID*.

Receipt

On receipt of the message the validation is carried out in accordance with *EDI-communication*.

Afterwards, the application is not allowed to reject the transactions.

2.3.8. UTILMD 432 - Dependency Matrix for Attributes

Attributes	RFT dependency				
	E01	E20	E05	Z14	Z15
IG version					
BT combined ID					
Market					
Message date					
Message function					
Message id					
Message name					
Message recipient					
Message sender					
Request for acknowledgement					
Time zone (UTC+0)					
Metering point id					
Reason for transaction					
Transaction id					
Contract stop date					
Consumer party contact address	R				
Meter reading	D*				
Reference to transaction		X		R	X

Table 15 BT-003: Dependency matrix for attributes: UTILMD 432

R= Required, D= Dependent, X= not used

* Meter reading is only filled if its available, otherwise, skip the segment

2.3.9. UTILMD 406 answer - Dependency Matrix for Attributes

Attributes	RFT dependency				
	E01	E20	Z14	Z15	E05
IG version					
BT combined ID					
Market					
Message date					
Message function					
Message id					
Message name					
Message recipient					
Message sender					
Request for acknowledgement					
Time zone (UTC+0)					
Metering point id					
Reason for transaction					
Transaction id					
Reference to transaction					
Status for answer					X
Reason for answer				D*	
Contract stop date				D**	R

Table 16 BT-003: Dependency matrix for attributes: UTILMD 406

R= Required, D= Dependent, X= Not used

* Only when Status for answer is 41 (rejected)

** Contract stop date is not used when Status for answer is 41 (rejected)

2.3.10. Unique Identification

BT ID	DK-BT-003
BT navn	End of Supply – to MPA
BT version	5
BT combined ID	DK-BT-003-005
BPI	DK-CUS
EDI Messages:	
Message ID	UTILMD 432
Message name	Notification of End of Supply
Message IG version	5.0 B
DK IG version	3
Message ID	UTILMD 406
Message name	Confirmation of End of Supply
Message IG version	5.0 B
DK IG version	3

2.3.11. Examples

UTILMD 432-E20 (End of Supply to Distribution Company for one metering point)

```
UNA:+. ? '
UNB+UNOC:3+5799999933318:14+5799999911118:14+031107:1300+UNIKT031++DK-
CUS+++DK '
UNH+1+UTILMD:D:02B:UN:E5DK03+DK-BT-003-005 '
BGM+432+MES031+9+NA '
DTM+137:200211071200:203 '
DTM+735: ?+0000:406 '
MKS+27+E01: :260 '
NAD+MS+5799999933318: :9 '
NAD+MR+5799999911118: :9 '
IDE+24+TrID31 '
DTM+93:200311300500:203 '
STS+7++E20: :260 '
LOC+172+571515199988888819: :9 '
UNT+12+1 '
UNZ+1+UNIKT031 '

```

UTILMD 406-E20 (Confirmation of End of Supply from Distribution Company for one metering point)

```
UNA:+. ? '
UNB+UNOC:3+5799999911118:14+5799999933318:14+020808:1200+UNIKT024++DK-
CUS+++DK '
UNH+1+UTILMD:D:02B:UN:E5DK03+DK-BT-003-005 '
BGM+406+MES023+9+NA '
DTM+137:200208081000:203 '
DTM+735: ?+0000:406 '
MKS+27+E01: :260 '
NAD+MS+5799999911118: :9 '
NAD+MR+5799999933318: :9 '
IDE+24+TrID24 '
DTM+93:200305300400:203 '
STS+7++E20: :260 '
STS+E01: :260+39 '
LOC+172+571515199988888819: :9 '
RFF+TN:TrID31 '
UNT+14+1 '
UNZ+1+UNIKT024 '

```

UTILMD 432-E20 (End of Supply to Distribution Company for more than one metering point)

```
UNA:+. ? '
UNB+UNOC:3+5799999933318:14+5799999911118:14+031107:1300+UNIKT032++DK-
CUS+++DK '
UNH+1+UTILMD:D:02B:UN:E5DK03+DK-BT-003-005 '
BGM+432+MES032+9+NA '
DTM+137:200211071200:203 '
DTM+735: ?+0000:406 '
MKS+27+E01: :260 '
NAD+MS+5799999933318: :9 '
NAD+MR+5799999911118: :9 '
IDE+24+TrID32 '
DTM+93:200311300500:203 '
STS+7++E20: :260 '
LOC+172+571515199988888819: :9 '
IDE+24+TrID33 '

```

DTM+93:200311300500:203 '
STS+7++E20::260 '
LOC+172+571515199988888819::9 '
UNT+16+1 '
UNZ+1+UNIKT032 '

UTILMD 432-E01 (Move)

UNA:+. ? '
UNB+UNOC:3+5790000333318:14+5791111333334:14+031001:1400+UNIKT001++DK-
CUS+++DK '
UNH+1+UTILMD:D:02B:UN:E5DK03+DK-BT-001-005 '
BGM+432+222+9+NA '
DTM+137:200303271352:203 '
DTM+735:?+0000:406 '
MKS+27+E01::260 '
NAD+MR+5790000333318::9 '
NAD+MS+5791111333334::9 '
IDE+24+10250907 '
DTM+93:200401010500:203 '
STS+7++E01::260 '
LOC+172+571515199988888819::9 '
SEQ++1 '
QTY+220:912569:MTQ '
NAD+UD+++John Jensen+Jensensvej::5+Fredericia++7000+DK '
UNT+15+1 '
UNZ+1+UNIKT001 '

Negative APERAK (answer to UTILMD 432-E20)

UNA:+. ? '
UNB+UNOC:3+5799999933318:14+5799999911118:14+031001:1432+UNIKT087++DK-
CUS+++DK '
UNH+1+APERAK:D:96A:UN:E2DK03+DK-BT-003-005 '
BGM+++34 '
DTM+137:200310011432:203 '
RFF+ACW:MES031 '
NAD+FR+5799999933318::9 '
NAD+DO+5799999911118::9 '
ERC+42::ZZZ '
FTX+AAO+++Stopdato ikke korrekt / Contract Stop date not correct,
12072003-0500
RFF+LI:TrID31 '
UNT+10+1 '
UNZ+1+UNIKT087 '

UTILMD 432-Z14 (End of Supply to Distribution Company for erroneous change of supplier)

UNA:+. ? '
UNB+UNOC:3+5799999933318:14+5799999911118:14+031107:1300+UNIKT031++DK-
CUS+++DK '
UNH+1+UTILMD:D:02B:UN:E5DK03+DK-BT-003-005 '
BGM+432+MES031+9+NA '
DTM+137:200211071200:203 '
DTM+735:?+0000:406 '
MKS+27+E01::260 '
NAD+MS+5799999933318::9 '
NAD+MR+5799999911118::9 '
IDE+24+TrID31 '
DTM+93:200311300500:203 '

STS+7++Z14::260'
LOC+172+571515199988888819::9'
UNT+12+1'
UNZ+1+UNIKT031'

2.4. BT-004: Master Data for Metering Point (UTILMD E07)

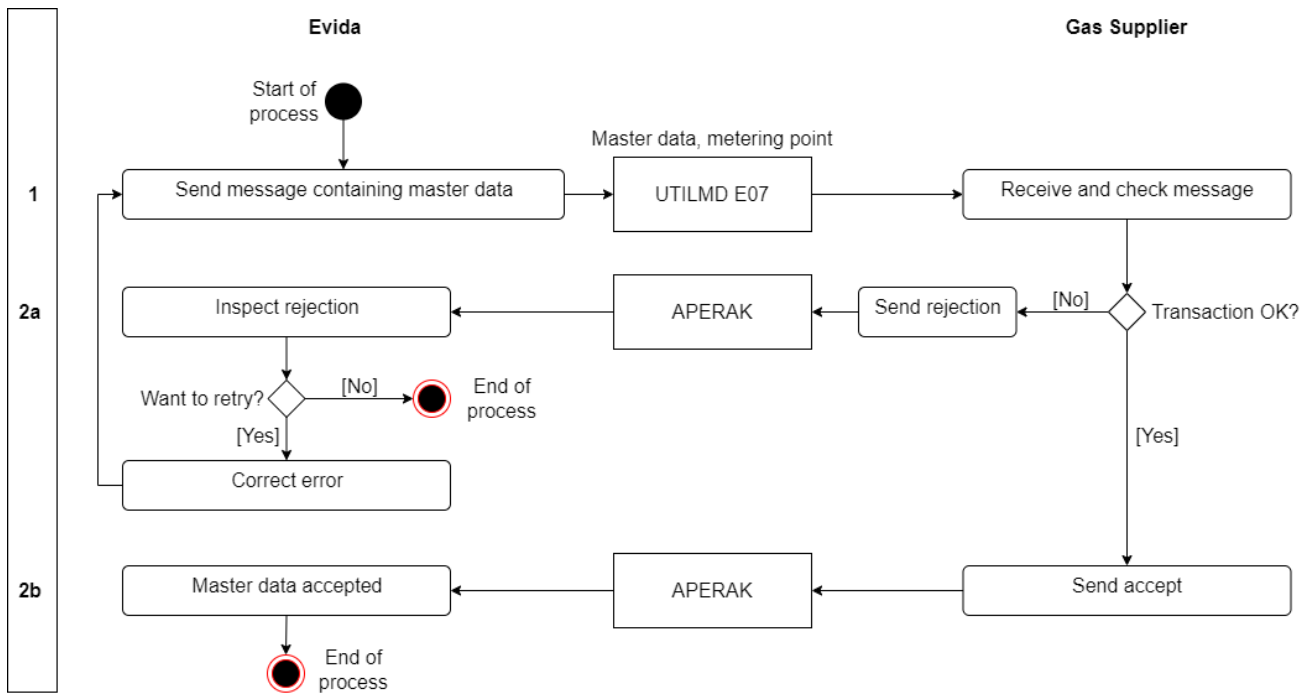

Figure 4: BT-004: Master Data Information for Metering Point (UTILMD E07)

Business Transaction BT-004 is used by Evida to send an EDI message containing master data for a *Metering point* to the *Gas Supplier*. It is also used to indicate that a change has been made to the metering point that the Gas Supplier shall be informed about.

2.4.1. Initiation of the transaction

The transaction is initiated by a *UTILMD* message with a document name code *E07* (*Master data, metering point*). The message can hold one or more transactions that all use different *Reason for Transaction (RFT)*. The value can be:

- E01 Move
- E03 Change of Supplier
- E20 End of Supply
- E32 Update of master data, metering point
- Z17 Secondary move in

- Z02 Change of meter location address
- Z03 Change of next scheduled meter reading date
- Z04 Change of estimated annual volume
- Z05 Change of consumer party name
- Z06 Change of physical status for metering point
- Z07 Change of settlement method

- Z14 Erroneous change of supplier
- Z15 Erroneous move

If RFT is Z07 this will also change the Next scheduled reading meter date. Additionally, if RFT is Z05 this may change the consumer party name, add a second consumer party name or remove a second consumer party name.

2.4.2. First dataflow: UTILMD E07

The message can be sent to and from Evida and the Gas Supplier.

In either case they must adhere to the dependency matrix.

Receipt

On receipt of the message the validation is carried out in accordance with *EDI-communication (Regulation F)*.

Afterwards, each transaction is verified in accordance with the business rules, which are documented in Table 17.

RFT	Validation	Error code
E32	The <i>Message Recipient</i> must be Gas Supplier to the <i>Metering point</i>	42 (Error in content of a data element)

Table 17: BT-004: Validation of first dataflow: UTILMD E07

As the message contains all master data for the metering point the receiver will only have to take the data that is relevant for the actual RFT. Trying to check the remaining data with present own values may result in errors if several changes have been made to a metering point and that the transactions are received in the wrong order.

2.4.3. Second dataflow: APERAK

If a transaction fulfils all the conditions in Table 17, it must be approved. This is done by sending a positive *APERAK* with *message function "34" (Accepted with amendment)*, the *error code "100" (The object is approved)* and "*Godkendt/Approved*" as *error description*. The transaction reference shall indicate the *Transaction ID*.

In case of verification failure, the transaction is rejected by a negative *APERAK* with *message function "34" (Accepted with amendment)* and the *error code* value indicated in the validation table. The name of the attribute that is the cause for failure must be stated in both Danish and English in the *error description*. The transaction reference shall indicate the *Transaction ID*.

Receipt

On receipt of the message the validation is carried out in accordance with *EDI-communication (Regulation F)*.

Afterwards, the application is not allowed to reject the transactions.

2.4.4. UTILMD E07 - Dependency Matrix for Attributes

Attributes	RFT
	ALL
IG version	R
BT combined ID	
Market	
Message date	
Message function	
Message id	
Message name	
Message recipient	
Message sender	
Request for acknowledgement	
Time zone (UTC+0)	
Metering point id	
Reason for transaction	
Transaction id	
Contract start date	
Validity start date	
Gas Supplier	
Estimated annual volume	
Consumer party name	R
Metering point address	
Settlement method	
Next scheduled meter reading date	D*
Physical status for metering point	R
Consumer party contact address	D**

Table 18 BT-004: Dependency matrix for attributes: UTILMD E07

R= Required, D= Dependent, X= Not used

* Only for profiled metering point

** Only for erroneous change of supplier

2.4.5. APERAK - Dependency Matrix for Attributes

Attributes	Dependency
IG version	R
BT combined ID	
Message date	
Message function	
Message recipient	
Message sender	
Reference to message	
Application error code	
Error description	
Transaction reference	

Table 19 BT-004: Dependency matrix for attributes: APERAK

R= Required

2.4.6. Unique Identification

BT ID	DK-BT-004
BT navn	Master Data Information for Metering Point
BT version	5
BT combined ID	DK-BT-004-005
BPI	DK-CUS
EDI Messages used	
Message ID	UTILMD E07
Message name	Master Data, metering point
Message IG version	5.0 B
DK IG version	3
Message ID	APERAK
Message name	Application error and acknowledgement message
Message IG version	2.4 B
DK IG version	3

2.4.7. Examples

UTILMD E07-E32 (Update of Master data)

```

UNA:+. ? '
UNB+UNOC:3+5799999911118:14+5799999933318:14+031001:1415+UNIKT042++DK-
CUS+++DK '
UNH+1+UTILMD:D:02B:UN:E5DK03+DK-BT-004-005 '
BGM+E07::260+MES042+9+AB '
DTM+137:200310011215:203 '
DTM+735: ?+0000:406 '
MKS+27+E01::260 '
NAD+MS+5799999911118::9 '
NAD+MR+5799999933318::9 '
IDE+24+TrID42 '
DTM+92:200301310500:203 '
DTM+157:200301310500:203 '

```

DTM+752:0301:106'
STS+7++E32::260'
LOC+172+571515199988888819::9'
CCI+++E02::260'
CAV+E01::260'
CCI+++E15::260'
CAV+E22::260'
SEQ++1'
QTY+31:6400:KWH'
NAD+DDQ+5799999933318::9'
NAD+IT++++::714;67;12;St;2+Fredericia++7000+DK'
NAD+UD+++Jens Jensen:Hanne Hansen'
IDE+24+TrID43'
DTM+92:200302280500:203'
DTM+157:200302280500:203'
DTM+752:0101:106'
DTM+752:0201:106'
DTM+752:0301:106'
DTM+752:0401:106'
DTM+752:0501:106'
DTM+752:0601:106'
DTM+752:0701:106'
DTM+752:0801:106'
DTM+752:0901:106'
DTM+752:1001:106'
DTM+752:1101:106'
DTM+752:1201:106'
STS+7++E32::260'
LOC+172+571515199988888825::9'
CCI+++E02::260'
CAV+E01::260'
CCI+++E15::260'
CAV+E22::260'
SEQ++1'
QTY+31:5000:KWH'
NAD+DDQ+5799999933318::9'
NAD+IT++++::631;43;12;St;2+vejle++7100+DK'
NAD+UD+++Hanne Hansen:Hans Hansen'
UNT+49+1'
UNZ+1+UNIKT042'

UTILMD E07-E06 (Unrequested Change of supplier)

UNA:+.?'
UNB+UNOC:3+5799999911118:14+5799999933318:14+031001:1415+UNIKT042++DK-
CUS+++DK'
UNH+1+UTILMD:D:02B:UN:E5DK03+DK-BT-004-005'
BGM+E07::260+MES042+9+AB'
DTM+137:200310011215:203'
DTM+735:?+0000:406'
MKS+27+E01::260'
NAD+MS+5799999911118::9'
NAD+MR+5799999933318::9'
IDE+24+TrID42'
DTM+92:200302010500:203'
DTM+157:200302010500:203'
DTM+752:0301:106'
STS+7++E06::260'
LOC+172+571515199988888819::9'
CCI+++E02::260'
CAV+E01::260'

CCI+++E15::260'
CAV+E22::260'
SEQ++1'
QTY+31:6400:KWH'
NAD+IT++++:::714;67;12;St;2+Fredericia++7000+DK'
NAD+UD+++Jens Jensen:Hanne Hansen+Kirkebakken:::5+Skive++7800+DK'
NAD+DDQ+5799999933318:::9'
UNT+22+1'
UNZ+1+UNIKT042'

UTILMD E07-Z06 (Change of physical status for metering point)

UNA:+.? '
UNB+UNOC:3+5799999911118:14+5799999933318:14+031001:1415+UNIKT041++DK-
CUS+++DK'
UNH+1+UTILMD:D:02B:UN:DKGAS1+DK-BT-004-005'
BGM+E07:::260+MES041+9+AB'
DTM+137:200310011215:203'
DTM+735:?+0000:406'
MKS+27+E01:::260'
NAD+MS+5799999911118:::9'
NAD+MR+5799999933318:::9'
IDE+24+TrID41'
DTM+92:200301310500:203'
DTM+157:200310030400:203'
DTM+752:0201:106'
STS+7++Z06::DK'
LOC+172+571515199988888819:::9'
CCI+++E02:::260'
CAV+E01:::260'
CCI+++E15:::260'
CAV+E22:::260'
SEQ++1'
QTY+31:6400:KWH'
NAD+DDQ+5799999933318:::9'
NAD+IT++++:::631;43;12;12;st;2+Fredericia++7000+DK'
NAD+UD+++Jens Jensen:Hanne Hansen'
UNT+23+1'
UNZ+1+UNIKT041'

Positive APERAK (answer to UTILMD E07-Z06)

UNA:+.? '
UNB+UNOC:3+5799999933318:14+5799999911118:14+031001:1432+UNIKT081++DK-
CUS+++DK'
UNH+1+APERAK:D:96A:UN:E2DK03+DK-BT-004-005'
BGM+++34'
DTM+137:200310011432:203'
RFF+ACW:MES041'
NAD+FR+5799999933318:::9'
NAD+DO+5799999911118:::9'
ERC+100:::ZZZ'
FTX+AAO+++Godkendt / Approved'
RFF+LI:TrID41'
UNT+10+1'
UNZ+1+UNIKT081'

Negative APERAK (answer to UTILMD E07-Z06)

UNA:+.? '

UNB+UNOC:3+5799999933318:14+5799999911118:14+031001:1432+UNIKT082++DK-
CUS+++DK'
UNH+1+APERAK:D:96A:UN:E2DK03+DK-BT-004-005'
BGM+++34'
DTM+137:200310011432:203'
RFF+ACW:MES041'
NAD+FR+5799999933318::9'
NAD+DO+5799999911118::9'
ERC+42::ZZZ'
FTX+AAO+++Målepunkt ikke kendt/ Meteringpoint not recognised:
123456789012345678' NB max 70 tegn
RFF+LI:TrID41'
UNT+10+1'
UNZ+1+UNIKT082'

2.5. BT-007: Consumption for Metering Point, profiled (MSCONS Z01)

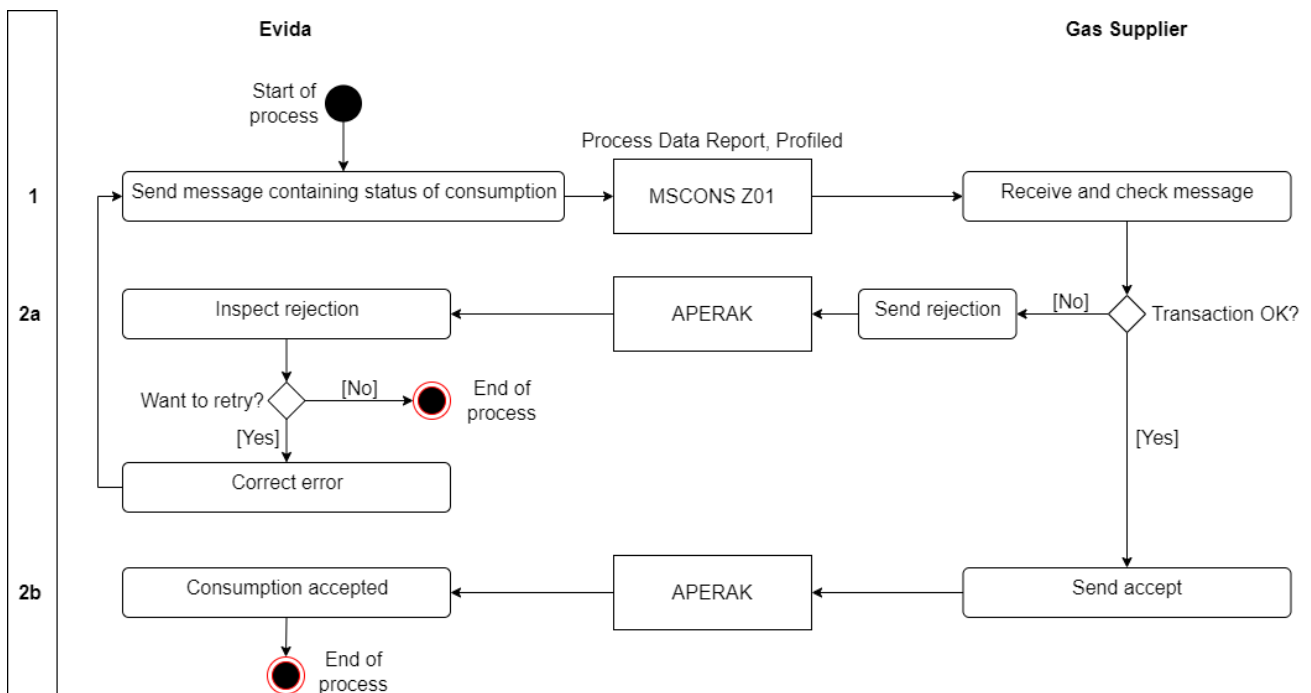

Figure 5: BT-007: Consumption for Metering Point, profiled (MSCONS Z01)

Business Transaction BT-007 is used by the *Evida* to send an EDI message containing status for consumption for a (profiled) *Metering point* to the *Gas Supplier*. *MSCONS Z01* can have the following functions:

- 9 Original
- 5 Replace (for corrections)

2.5.1. Initiation of the transaction

The transaction is initiated by an *MSCONS Z01 (Process Data Report, Profiled)* message. The message can hold one or more transactions that all use the same *Reason for Meter Reading (RFMR)*. The values can be:

- 1 (*Periodical*) – used for normal statement of consumption.
- 2 (*Change of supplier*) – used for final settlement.
- 3 (*Non-Periodical*) – used for settlement purpose outside normal meter reading period.
- 9 (*Change of settlement method*) - used when settlement is changed from profiled to metered.

2.5.2. First dataflow: MSCONS Z01

The message is sent with data as referred to in the dependency matrix (see section 2.5.4).

Receipt

On receipt of the message the validation is carried out in accordance with *EDI-communication (Regulation F)*.

Afterwards, each transaction is verified in accordance with the business rules, which are documented in Table 20.

RFMR	Validation	Error code
1 2 3 9	The <i>Message Recipient</i> must be <i>Gas Supplier</i> to the <i>Metering point</i>	42 (Error in content of a data element)
1 2 3 9	Quantity has not been received before for the metered time interval, unless message function is '5'	42 (Error in content of a data element)
1 2 3	<i>Quantity time intervals</i> must be consecutive (no "holes", no "overlap") in relation to previous received <i>Quantity</i> .	42 (Error in content of a data element)
9	The end of <i>Quantity time interval</i> must equal to <i>Validity start date</i> in BS-212 (gas)	42 (Error in content of a data element)
1 2 3 9	The <i>Measure unit</i> must be kWh or MTQ.	42 (Error in content of a data element)
1 2 3 9	Quantity must be without decimals	42 (Error in content of a data element)
1 2 3	In the case of consumption the sign of quantity for the period is positive	42 (Error in content of a data element)

Table 20: BT-007: Validation of first dataflow: MSCONS Z01

2.5.3. Second dataflow: APERAK

If a transaction fulfils all the conditions in Table 20, it must be approved. This is done by sending a positive *APERAK* with *message function* "34" (*Accepted with amendment*), the *error code* "100" (*The object is approved*) and "Godkendt/Approved" as *error description*. The transaction reference shall indicate the *Transaction ID*.

In case of verification failure, the transaction is rejected by a negative *APERAK* with *message function* "34" (*Accepted with amendment*) and the *error code* value indicated in the validation table. The name of the attribute that is the cause for failure must be stated in both Danish and English in the *error description*. The transaction reference shall indicate the *Transaction ID*.

Receipt

On receipt of the message the validation is carried out in accordance with *EDI-communication (Regulation F)*.

Afterwards, the application is not allowed to reject the transactions.

2.5.4. MSCONS Z01 - Dependency Matrix for Attributes

Attributes	Dependency
IG version	R
BT combined ID	
Message date	
Message function (9 or 5)	
Message id	
Message name	
Message recipient	
Message sender	
Request for acknowledgement	
Time zone (UTC+0)	
Metered time interval	
Metering point id	
Product code	
Measure unit	
Quantity time interval	
Quantity	
Quantity status code	
Reason for meter reading	

Table 21 BT-007: Dependency matrix for attributes: MSCONS Z01

R= Required

2.5.5. APERAK - Dependency Matrix for Attributes

Attributes	Depen-dency
IG version	R
BT combined ID	
Message date	
Message function	
Message recipient	
Message sender	
Reference to message	
Application error code	
Error description	

Table 22 BT-007: Dependency matrix for attributes: APERAK

R= Required

2.5.6. Unique Identification

BT ID	DK-BT-007
BT navn	Consumption for Metering Point, Profiled
BT version	5
BT combined ID	DK-BT-007-005
BPI	DK-CUS
EDI Messages:	
Message ID	MSCONS Z01
Message name	Process Data Report, profiled
Message IG version	2.4 D
DK IG version	3
Message ID	APERAK
Message name	Application error and acknowledgement message
Message IG version	2.4 B
DK IG version	3

2.5.7. Examples

MSCONS Z01: Consumption for one profiled Metering Point

```

UNA:+. ? '
UNB+UNOC:3+5799999911118:14+5799999933318:14+040104:1315+UNIKT071++DK-
CUS+++DK'
UNH+1+MSCONS:D:96A:ZZ:E2DK03+DK-BT-007-005'
BGM+Z01::260+444+9+AB'
DTM+137:200303271505:203'
DTM+163:200212310500:203'
DTM+164:200331210500:203'
DTM+ZZZ:0:805'
NAD+FR+5799999911118::9'
NAD+DO+5799999933318::9'
UNS+D'
NAD+XX'

```

LOC+90+571515199988888833::9'
LIN+1++3002:::DK'
MEA+AAZ++KWH'
QTY+136:7400'
DTM+324:200212310500200312310500:Z13'
CCI+++Z04'
MEA+SV++ZZ:1'
LIN+2++3004:::DK'
MEA+AAZ++MTQ'
QTY+136:672'
DTM+324:200212310500200312310500:Z13'
CCI+++Z04'
MEA+SV++ZZ:1'
CNT+1:8072'
UNT+25+1'
UNZ+1+UNIKT071'

Positive APERAK (answer to MSCONS Z01)

UNA:+.?'
UNB+UNOC:3+5799999933318:14+5799999911118:14+031001:1432+UNIKT091++DK-
CUS+++DK'
UNH+1+APERAK:D:96A:UN:E2DK03+DK-BT-007-005'
BGM+++34'
DTM+137:200310011432:203'
RFF+ACW:MES071'
NAD+FR+5799999933318::9'
NAD+DO+5799999911118::9'
ERC+100::ZZZ'
FTX+AAO+++Godkendt / Approved'
RFF+AES:571515199988888819'
UNT+10+1'
UNZ+1+UNIKT091'

Negative APERAK (answer to MSCONS Z01)

UNA:+.?'
UNB+UNOC:3+5799999933318:14+5799999911118:14+031001:1432+UNIKT092++DK-
CUS+++DK'
UNH+1+APERAK:D:96A:UN:E2DK03+DK-BT-007-005'
BGM+++34'
DTM+137:200310011432:203'
RFF+ACW:MES071'
NAD+FR+5799999933318::9'
NAD+DO+5799999911118::9'
ERC+42::ZZZ'
FTX+AAO+++Målepunkt ikke kendt / Meteringpoint not recognised:
123456789012345678'
RFF+AES:571515199988888819'
UNT+10+1'
UNZ+1+UNIKT092'

MSCONS Z01 (Consumption for one profiled Metering Point, reason: Change of Supplier)

UNA:+.?'
UNB+UNOC:3+5799999911118:14+5799999933318:14+040104:1315+UNIKT071++DK-
CUS+++DK'
UNH+1+MSCONS:D:96A:ZZ:E2DK03+DK-BT-007-005'
BGM+Z01::260+444+9+AB'

DTM+137:200303271505:203'
DTM+163:200212310500:203'
DTM+164:200331210500:203'
DTM+ZZZ:0:805'
NAD+FR+5799999911118::9'
NAD+DO+5799999933318::9'
UNS+D'
NAD+XX'
LOC+90+571515199988888833::9'
LIN+1++3002:::DK'
MEA+AAZ++KWH'
QTY+136:7400'
DTM+324:200212310500200312310500:Z13'
CCI+++Z04'
MEA+SV++ZZ:2'
LIN+2++3004:::DK'
MEA+AAZ++MTQ'
QTY+136:672'
DTM+324:200212310500200312310500:Z13'
CCI+++Z04'
MEA+SV++ZZ:2'
CNT+1:8072'
UNT+25+1'
UNZ+1+UNIKT071'

2.6. BT-008: Time series transmission (MSCONS 7)

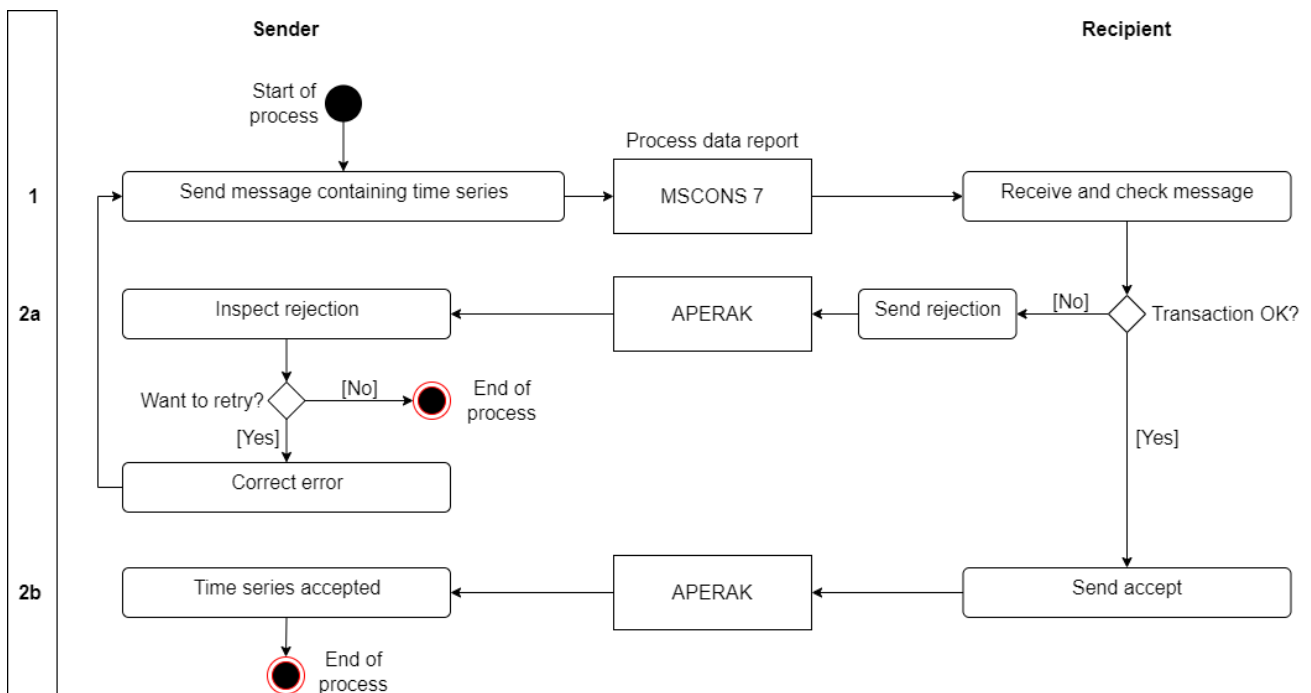

Figure 6: BT-008: Report time series (MSCONS 7)

Business Transaction, BT-008 is a general transaction used by *Evida* or other parties to send an EDI message containing one or more time series to a receiving party. The receiving party could be: a Gas Supplier, a Shipper, a Transmission System Operator, Evida or any other party which is entitled to receive such data.

Being a generic transaction, it is not possible to specify all specific dependency and validation in this documentation. The processing is instead relying on dependencies specified in the product code specification that can be found in the list of Danish ebIX product codes or has been bilaterally defined.

All IT-system must enable the users to set up time series and documents in a flexible way so time series for all types of product codes can be implemented by the users themselves.

The BT-008 has been changed so that it is now possible to send more information about one Serial ID; instead of using NAD+XX, this transaction will be using LIN+ lineno at the beginning of a repetition.

2.6.1. Initiation of the transaction

The transaction is initiated by a *MSCONS 7 (Process Data Report, Time Series)* message. The message can hold one or more time series.

Time series can be *dynamic* or *non-dynamic*. Dynamic time series can be sent without notice to the receiver. Time series with consumption for *Metering points (metered) (product code 9012)* is a dynamic time series. All other time series are non-dynamic.

Before sending non-dynamic time series, the receiver must be informed of the *Serial ID* to be used for the time series and its relevant master data. Master data includes:

- Serial ID (set by sender)
- Time zone to be used (UTC is recommended)
- Product code

- Actual value of *Company* attributes
- Actual value of *Area* attributes
- Measure unit and precision to be used (kWh with up to 3 decimals if not otherwise agreed)
- Length of quantity time interval

It may also be bilateral agreed to use automatic receipt of corrected values indicated by message function = 5 (see section 2.6.2).

2.6.2. First dataflow: MSCONS 7

The message is sent with data as referred to in the dependency matrix. Please note that most dependencies are specified by the product code. MSCONS 7 can have the following *functions*:

- 9 Original
- 5 Replace (for corrections)

Receipt

On receipt of the message the validation is carried out in accordance with *EDI-communication (Regulation F)*.

Afterwards, each time series is verified in accordance with the business rules, which are documented in Table 23.

Validation	Error code
Time zone for the message must be equal to that specified in the master data for the <i>Serial ID</i>	42 (Error in content of a data element)
The <i>Message Recipient</i> must be <i>Gas Supplier</i> to the <i>Metering point</i> for <i>product code 9012 (electricity)</i> or <i>product code 3002/3004/3006 (gas)</i>	42 (Error in content of a data element)
The <i>Serial ID</i> and the master data must be informed beforehand (except for dynamic time series)	42 (Error in content of a data element)
The <i>Product code</i> must be equal to that specified in the master data for the <i>Serial ID</i>	42 (Error in content of a data element)
The <i>Area 1</i> (if required) must be equal to that specified in the master data for the <i>Serial ID</i>	42 (Error in content of a data element)
The <i>Area 2</i> (if required) must be equal to that specified in the master data for the <i>Serial ID</i>	42 (Error in content of a data element)
The <i>Company 1</i> (if required) must be equal to that specified in the master data for the <i>Serial ID</i>	42 (Error in content of a data element)
The <i>Company 2</i> (if required) must be equal to that specified in the master data for the <i>Serial ID</i>	42 (Error in content of a data element)
The <i>Measure unit</i> must be equal to that specified in the master data for the <i>Serial ID</i>	42 (Error in content of a data element)
The <i>Quantity time intervals</i> must be within <i>Metered time interval</i>	42 (Error in content of a data element)
The <i>Quantity time intervals</i> must have the length specified in the master data for the <i>Serial ID</i>	42 (Error in content of a data element)
<i>Quantity time intervals</i> must be consecutive (no "holes" and no "overlap") and always with ascending intervals	42 (Error in content of a data element)
The precision (number of decimals) of the <i>Quantity</i> must be less or equal to what is specified in the master data for the <i>Serial ID</i>	42 (Error in content of a data element)
The <i>Quantity status code</i> must be 99, 136, Z01.	42 (Error in content of a data element)

Table 23: Validation of first dataflow: MSCONS 7

2.6.3. Second dataflow: APERAK

If a time series fulfils all the conditions in Table 23, it must be approved. This is done by sending a positive *APERAK* with *message function* “34” (*Accepted with amendment*), the *error code* “100” (*The object is approved*) and “Godkendt/Approved” as *error description*. The transaction reference shall indicate the *Serial ID*.

In case of verification failure, the time series is rejected by a negative *APERAK* with *message function* “34” (*Accepted with amendment*) and the *error code* value indicated in the validation table. The name of the attribute that is the cause for failure must be stated in both Danish and English in the *error description*. The transaction reference shall indicate the *Serial ID*.

Receipt

On receipt, the *APERAK* is validated according to *EDI-communication (Regulation F)*.

Afterwards, the application is not allowed to reject the transactions in the *APERAK*.

2.6.4. MSCONS 7 - Dependency Matrix for Attributes

Attributes	
IG version	R
BT combined ID	R
Message date	R
Message function (9 or 5)	R
Message id	R
Message name	R
Message recipient	R
Message sender	R
Request for acknowledgement	R
Time zone	R
Metered time interval	R
Serial ID	R
Product code	R
Area 1	D*
Area 2	D*
Company 1	D*
Company 2	D*
Measure unit	R
Quantity time interval	R
Quantity	R
Quantity status code	R

Table 24: BT-008: Dependency matrix for attributes: MSCONS 7

* Dependency specified in the product code list

R= Required, D= Dependent

2.6.5. APERAK - Dependency Matrix for Attributes

Attributes	
IG version	R
BT combined ID	
Message date	
Message function	
Message recipient	
Message sender	
Reference to message	
Application error code	
Error description	
Transaction reference	

Table 25: BT-008: Dependency matrix for attributes: APERAK

R= Required

2.6.6. Unique Identification

BT ID	DK-BT-008
BT name	Time series transmission
BT version	5
BT combined ID	DK-BT-008-005
BPI	DK-TIS-MET
EDI Messages:	
Message ID	MSCONS 7
Message name	Process Data Report, time series
Message IG version	3.1
DK IG version	3
Message ID	APERAK
Message name	Application error and acknowledgement message
Message IG version	3.1
DK IG version	3

2.6.7. Examples

MSCONS 7 (Consumption data from Distribution Company to Supplier)

```

UNA:+. ? '
UNB+UNOC:3+5799999911118:14+5799999933318:14+031126:1233+E233510++DK-TIS-
MET+++DK '
UNH+1+MSCONS:D:96A:ZZ:E2DK03+DK-BT-008-005 '
BGM+7+E99989+9+AB '
DTM+137:201304261131:203 '
DTM+163:201304230400:203 '
DTM+164:201304240400:203 '
DTM+ZZZ:0:805 '
NAD+FR+5799999911118::9 '
NAD+DO+5799999933318::9 '
UNS+D '
NAD+XX '
LOC+90+571515199988888833::9 '
LIN+1++3001:::DK '
MEA+AAZ++KWH '

```

QTY+136:1000'
DTM+324:201304230400201304230500:Z13'
QTY+136:1000'
DTM+324:201304230500201304230600:Z13'
QTY+136:1000'
DTM+324:201304230600201304230700:Z13'
QTY+136:1000'
DTM+324:201304230700201304230800:Z13'
QTY+136:1000'
DTM+324:201304230800201304230900:Z13'
QTY+136:1000'
DTM+324:201304230900201304231000:Z13'
QTY+136:2000'
DTM+324:201304231000201304231100:Z13'
QTY+136:2000'
DTM+324:201304231100201304231200:Z13'
QTY+136:2000'
DTM+324:201304231200201304231300:Z13'
QTY+136:2000'
DTM+324:201304231300201304231400:Z13'
QTY+136:2000'
DTM+324:201304231400201304231500:Z13'
QTY+136:2000'
DTM+324:201304231500201304231600:Z13'
QTY+136:2000'
DTM+324:201304231600201304231700:Z13'
QTY+136:2000'
DTM+324:201304231700201304231800:Z13'
QTY+136:2000'
DTM+324:201304231800201304231900:Z13'
QTY+136:2000'
DTM+324:201304231900201304232000:Z13'
QTY+136:2000'
DTM+324:201304232000201304232100:Z13'
QTY+136:500'
DTM+324:201304232100201304232200:Z13'
QTY+136:500'
DTM+324:201304232200201304232300:Z13'
QTY+136:500'
DTM+324:201304232300201304240000:Z13'
QTY+136:500'
DTM+324:201304240000201304240100:Z13'
QTY+136:500'
DTM+324:201304240100201304240200:Z13'
QTY+136:500'
DTM+324:201304240200201304240300:Z13'
QTY+136:500'
DTM+324:201304240300201304240400:Z13'
LIN+2++3003:::DK'
MEA+AAZ++MTQ'
QTY+136:1000'
DTM+324:201304230400201304230500:Z13'
QTY+136:1000'
DTM+324:201304230500201304230600:Z13'
QTY+136:1000'
DTM+324:201304230600201304230700:Z13'
QTY+136:1000'
DTM+324:201304230700201304230800:Z13'
QTY+136:1000'
DTM+324:201304230800201304230900:Z13'
QTY+136:1000'

DTM+324:201304230900201304231000:Z13 '
 QTY+136:2000 '
 DTM+324:201304231000201304231100:Z13 '
 QTY+136:2000 '
 DTM+324:201304231100201304231200:Z13 '
 QTY+136:2000 '
 DTM+324:201304231200201304231300:Z13 '
 QTY+136:2000 '
 DTM+324:201304231300201304231400:Z13 '
 QTY+136:2000 '
 DTM+324:201304231400201304231500:Z13 '
 QTY+136:2000 '
 DTM+324:201304231500201304231600:Z13 '
 QTY+136:2000 '
 DTM+324:201304231600201304231700:Z13 '
 QTY+136:2000 '
 DTM+324:201304231700201304231800:Z13 '
 QTY+136:2000 '
 DTM+324:201304231800201304231900:Z13 '
 QTY+136:2000 '
 DTM+324:201304231900201304232000:Z13 '
 QTY+136:2000 '
 DTM+324:201304232000201304232100:Z13 '
 QTY+136:500 '
 DTM+324:201304232100201304232200:Z13 '
 QTY+136:500 '
 DTM+324:201304232200201304232300:Z13 '
 QTY+136:500 '
 DTM+324:201304232300201304240000:Z13 '
 QTY+136:500 '
 DTM+324:201304240000201304240100:Z13 '
 QTY+136:500 '
 DTM+324:201304240100201304240200:Z13 '
 QTY+136:500 '
 DTM+324:201304240200201304240300:Z13 '
 QTY+136:500 '
 DTM+324:201304240300201304240400:Z13 '
 CNT+1:31500 '
 UNT+115+1 '
 UNZ+1+ E233510 '

MSCONS 7 (Calorific values)

Notice that the LOC segment is to be repeated for each M/R Station. The LIN segment is used twice for each M/R Station; first for the daily values (thirty-one times 24-hour values), and secondly for the monthly average (one value). The underlying SG 10 (QTY & DTM) is to be repeated for each time period.

UNA:+. ? '
 UNB+UNOC:3+5799999911118:14+5799999933318:14+031126:1233+E233510++DK-TIS-
 MET+++DK '
 UNH+127+MSCONS:D:96A:ZZ:E2DK03+DK-BT-008-005 '
 BGM+7+REF6262+9+AB '
 DTM+137:200410021540:203 '
 DTM+163:200409010400:203 '
 DTM+164:200410010400:203 '
 DTM+ZZZ:0:805 '
 NAD+FR+5799999911118::9 '
 NAD+DO+5799999933318::9 '
 UNS+D '
 NAD+XX '

LOC+90+579111122222312323::9'
LIN+1++3007:::DK'
MEA+AAZ++Z15'
QTY+136:12.234'
DTM+324:200409010400200409020400:Z13'
QTY+136:12.133'
DTM+324:200409020400200409030400:Z13'
QTY+136:12.235'
DTM+324:200409030400200409040400:Z13'
...
QTY+136:12.338'
DTM+324:200409300400200410010400:Z13'
LIN+2++3008:::DK'
MEA+AAZ++Z15'
QTY+136:12.234'
DTM+324:200409010400200410010400:Z13'
NAD+XX'
LOC+90+579111122222312357::9'
LIN+1++3007:::DK'
MEA+AAZ++Z15'
QTY+136:12.133'
DTM+324:200409010400200409020400:Z13'
...
QTY+136:12.238'
DTM+324:200409300400200410010400:Z13'
LIN+2++3008:::DK'
MEA+AAZ++Z15'
QTY+136:12.194'
DTM+324:200409010400200410010400:Z13'
CNT+1:787.936'
UNT+125+127'
UNZ+1+E233510'

MSCONS 7 Adjusted Residual Consumption

UNA:+.?'
UNB+UNOC:3+5799999911118:14+5799999933318:14+031126:1233+E233510++DK-TIS-MET+++DK'
UNH+127+MSCONS:D:96A:ZZ:E2DK03+DK-BT-008-005'
BGM+7+REF6262+9+AB'
DTM+137:200410121540:203'
DTM+163:200409010400:203'
DTM+164:200410010400:203'
DTM+ZZZ:0:805'
NAD+FR+5799999911118::9'
NAD+DO+5799999933318::9'
UNS+D'
NAD+XX'
LOC+90+579551122222312323::9'
LIN+1++1082:::DK'
MEA+AAZ++KWH'
QTY+136:757125125.343'
DTM+324:200409010400200410010400:Z13'
CNT+1:757125125.343'
UNT+16+127'
UNZ+1+E233510'

MSCONS 7 (M/R Consumption)

Notice that the LOC segment is to be repeated for each M/R station. LIN can be repeated if there is more information for each M/R station. The underlying SG 10 (QTY & DTM) is to be repeated for each time period.

```

UNA:+. ? '
UNB+UNOC:3+5799999911118:14+5799999933318:14+031126:1233+E233510++DK-TIS-
MET+++DK '
UNH+127+MSCONS:D:96A:ZZ:E2DK03+DK-BT-008-005 '
BGM+7+REF6262+9+AB '
DTM+137:200409151540:203 '
DTM+163:200409150400:203 '
DTM+164:200409160400:203 '
DTM+ZZZ:0:805 '
NAD+FR+5799999911118::9 '
NAD+DO+5799999933318::9 '
UNS+D '
NAD+XX '
LOC+90+579111122222312323::9 '
LIN+1++3030:::DK '
MEA+AAZ++KWH '
QTY+136:125.34 '
DTM+324:200409150400200409150500:Z13 '
QTY+136:225.34 '
DTM+324:200409150500200409150600:Z13 '
QTY+136:121.34 '
DTM+324:200409150600200409150700:Z13 '
...
QTY+136:25.34 '
DTM+324:200409160300200409160400:Z13 '
NAD+XX '
LOC+90+579111122222312357::9 '
LIN+1++3030:::DK '
MEA+AAZ++KWH '
QTY+136:725.34 '
DTM+324:200409150400200409150500:Z13 '
QTY+136:825.34 '
DTM+324:200409150500200409150600:Z13 '
...
CNT+1:6864.78 '
UNT+204+127 '
UNZ+1+E233510 '

```

MSCONS 7 (Gas Flow Adjustments)

```

UNA:+. ? '
UNB+UNOC:3+5799999911118:14+5799999933318:14+031126:1233+E233510++DK-TIS-
MET+++DK '
UNH+127+MSCONS:D:96A:ZZ:E2DK03+DK-BT-008-005 '
BGM+7+REF6262+9+AB '
DTM+137:200409151540:203 '
DTM+163:200409150400:203 '
DTM+164:200409160400:203 '
DTM+ZZZ:0:805 '
NAD+FR+5799999911118::9 '
NAD+DO+5799999933318::9 '
UNS+D '
NAD+XX '
LOC+90+579111122222312323::9 '
LIN+1++3060:::DK '
MEA+AAZ++KWH '
QTY+136:125.34 '

```

DTM+324:200409150400200409150500:Z13 '
 QTY+136:225.34 '
 DTM+324:200409150500200409150600:Z13 '
 QTY+136:121.34 '
 DTM+324:200409150600200409150700:Z13 '
 ...
 QTY+136:-25.34 '
 DTM+324:200409160300200409160400:Z13 '
 CNT+1:6864.78 '
 UNT+63+127 '
 UNZ+1+E233510 '

MSCONS 7 (DMS Consumption)

Notice that the LOC segment is to be repeated for each VRP. The underlying SG 10 (QTY & DTM) is to be repeated for each time period.

UNA:+. ? '
 UNB+UNOC:3+5799999911118:14+5799999933318:14+031126:1233+E233510++DK-TIS-MET+++DK '
 UNH+127+MSCONS:D:96A:ZZ:E2DK03+DK-BT-008-005 '
 BGM+7+REF6262+9+AB '
 DTM+137:200409161540:203 '
 DTM+163:200409150400:203 '
 DTM+164:200409160400:203 '
 DTM+ZZZ:0:805 '
 NAD+FR+5799999911118::9 '
 NAD+DO+5799999933318::9 '
 UNS+D '
 NAD+XX '
 LOC+90+57922112222312323::9 '
 LIN+1++3040:::DK '
 MEA+AAZ++KWH '
 QTY+136:125.34 '
 DTM+324:200409150400200409150500:Z13 '
 QTY+136:225.34 '
 DTM+324:200409150500200409150600:Z13 '
 QTY+136:121.34 '
 DTM+324:200409150600200409150700:Z13 '
 ...
 QTY+136:25.34 '
 DTM+324:200409160300200409160400:Z13 '
 NAD+XX '
 LOC+90+57933112222312357::9 '
 LIN+1++3040:::DK '
 MEA+AAZ++KWH '
 QTY+136:725.34 '
 DTM+324:200409Z50400200409150500:Z13 '
 QTY+136:825.34 '
 DTM+324:200409150500200409150600:Z13 '
 ...
 CNT+1:6864.78 '
 UNT+204+127 '
 UNZ+1+E233510 '

MSCONS 7 (Residual Consumption to Transmission)

Notice that the LOC segment is to be repeated for each VRP and Lin if there is more information.

UNA:+. ? '

UNB+UNOC:3+5799999911118:14+5799999933318:14+031126:1233+E233510++DK-TIS-MET+++DK'
UNH+127+MSCONS:D:96A:ZZ:E2DK03+DK-BT-008-005'
BGM+7+REF6262+9+AB'
DTM+137:200409161540:203'
DTM+163:200409150400:203'
DTM+164:200409160400:203'
DTM+ZZZ:0:805'
NAD+FR+5799999911118::9'
NAD+DO+5799999933318::9'
UNS+D'
NAD+XX'
LOC+90+579221122222312323::9'
LIN+1++3050:::DK'
MEA+AAZ++KWH'
QTY+136:125.34'
DTM+324:200409150400200409160400:Z13'
NAD+XX'
LOC+90+579331122222312357::9'
LIN+1++3050:::DK'
MEA+AAZ++KWH'
QTY+136:725.34'
DTM+324:200409150400200409160400:Z13'
CNT+1:6864.78'
UNT+22+127'
UNZ+1+E233510'

MSCONS 7 (Residual Consumption to Supplier)

Notice that the LOC segment is to be repeated for each Distribution zone.

UNA:+.?'
UNB+UNOC:3+5799999911118:14+5799999933318:14+031126:1233+E233510++DK-TIS-MET+++DK'
UNH+127+MSCONS:D:96A:ZZ:E2DK03+DK-BT-008-005'
BGM+7+REF6262+9+AB'
DTM+137:200409161540:203'
DTM+163:200409150400:203'
DTM+164:200409160400:203'
DTM+ZZZ:0:805'
NAD+FR+5799999911118::9'
NAD+DO+5799999933318::9'
UNS+D'
NAD+XX'
LOC+90+579551122222312323::9'
LIN+1++3020:::DK'
MEA+AAZ++KWH'
QTY+136:125125.34'
DTM+324:200409150400200409160400:Z13'
CNT+1:125125.34'
UNT+16+127'
UNZ+1+E233510'

MSCONS 7 (Reconciliation - to Transmission)

Notice that the LOC segment is to be repeated for each VRP.

UNA:+.?'
UNB+UNOC:3+5799999911118:14+5799999933318:14+031126:1233+E233510++DK-TIS-MET+++DK'

UNH+127+MSCONS:D:96A:ZZ:E2DK03+DK-BT-008-005'
BGM+7+REF6262+9+AB'
DTM+137:200410051540:203'
DTM+163:200409010400:203'
DTM+164:200410010400:203'
DTM+ZZZ:0:805'
NAD+FR+5799999911118::9'
NAD+DO+5799999933318::9'
UNS+D'
NAD+XX'
LOC+90+579221122222312323::9'
LIN+1++3011:::DK'
MEA+AAZ++KWH'
QTY+136:125125.125'
DTM+324:200409010400200410010400:Z13'
LIN+2++3012:::DK'
MEA+AAZ++KWH'
QTY+136:33333333.222'
DTM+324:200409010400200410010400:Z13'
NAD+XX'
LOC+90+579221122222312357::9'
LIN+1++3011:::DK'
MEA+AAZ++KWH'
QTY+136:-27.127'
DTM+324:200409010400200410010400:Z13'
LIN+2++3012:::DK'
MEA+AAZ++KWH'
QTY+136:444444.333'
DTM+324:200409010400200410010400:Z13'
CNT+1:333902875.553'
UNT+29+127'
UNZ+1+E233510'

MSCONS 7 (Reconciliation - to Supplier)

UNA:+.? '
UNB+UNOC:3+5799999911118:14+5799999933318:14+031126:1233+E233510++DK-TIS-
MET+++DK'
UNH+127+MSCONS:D:96A:ZZ:E2DK03+DK-BT-008-005'
BGM+7+REF6262+9+AB'
DTM+137:200410051540:203'
DTM+163:200409010400:203'
DTM+164:200410010400:203'
DTM+ZZZ:0:805'
NAD+FR+5799999911118::9'
NAD+DO+5799999933318::9'
UNS+D'
NAD+XX'
LOC+90+579331122222312357::9'
LIN+1++3011:::DK'
MEA+AAZ++KWH'
QTY+136:-444318.778'
DTM+324:200409010400200410010400:Z13'
LIN+2++3012:::DK'
MEA+AAZ++KWH'
QTY+136:444444.333'
DTM+324:200409010400200410010400:Z13'
LIN+3++3050:::DK'
MEA+AAZ++KWH'
QTY+136:125.555'
DTM+324:200409010400200410010400:Z13'

CNT+1:251.110'
UNT+24+127'
UNZ+1+E233510'

Positive APERAK (answer to MSCONS 7 - Consumption data from Distribution Company to Supplier)

UNA:+.? '
UNB+UNOC:3+5799999933318:14+5799999911118:14+031126:1247+UNIKT095++DK-TIS-MET+++DK'
UNH+1+APERAK:D:96A:UN:E2DK03+DK-BT-008-005'
BGM+++34'
DTM+137:200311261246:203'
RFF+ACW:E99989'
NAD+FR+5799999933318::9'
NAD+DO+5799999911118::9'
ERC+100::ZZZ'
FTX+AAO+++Godkendt / Approved'
RFF+AES:571515199988888833'
UNT+10+1'
UNZ+1+UNIKT095'

Negative APERAK (answer to MSCONS 7 - Consumption data from Distribution Company to Supplier)

UNA:+.? '
UNB+UNOC:3+5799999933318:14+5799999911118:14+031126:1247+UNIKT096++DK-TIS-MET+++DK'
UNH+1+APERAK:D:96A:UN:E2DK03+DK-BT-008-005'
BGM+++34'
DTM+137:200311261246:203'
RFF+ACW:E99989'
NAD+FR+5799999933318::9'
NAD+DO+5799999911118::9'
ERC+42::ZZZ'
FTX+AAO+++Ansvarlig for målepunkt ikke kendt/ Responsible for Meteringpoint not recognised: 14'
RFF+AES:571515199988888833'
UNT+10+1'
UNZ+1+UNIKT096'

Negative APERAK (answer to MSCONS 7 - Consumption data from Distribution Company to Supplier)

UNA:+.? '
UNB+UNOC:3+5799999933318:14+5799999911118:14+031126:1247+UNIKT096++DK-TIS-MET+++DK'
UNH+1+APERAK:D:96A:UN:E2DK03+DK-BT-008-005'
BGM+++27'
DTM+137:200311261246:203'
RFF+ACW:E99989'
NAD+FR+5799999933318::9'
NAD+DO+5799999911118::9'
ERC+42::ZZZ'
FTX+AAO+++Ukendt Combined Id / Unknown Combined Id: DK-BT-099-004'
UNT+9+1'
UNZ+1+UNIKT096'

2.7. BT-009: Reconciliation data transmission (MSCONS 7)

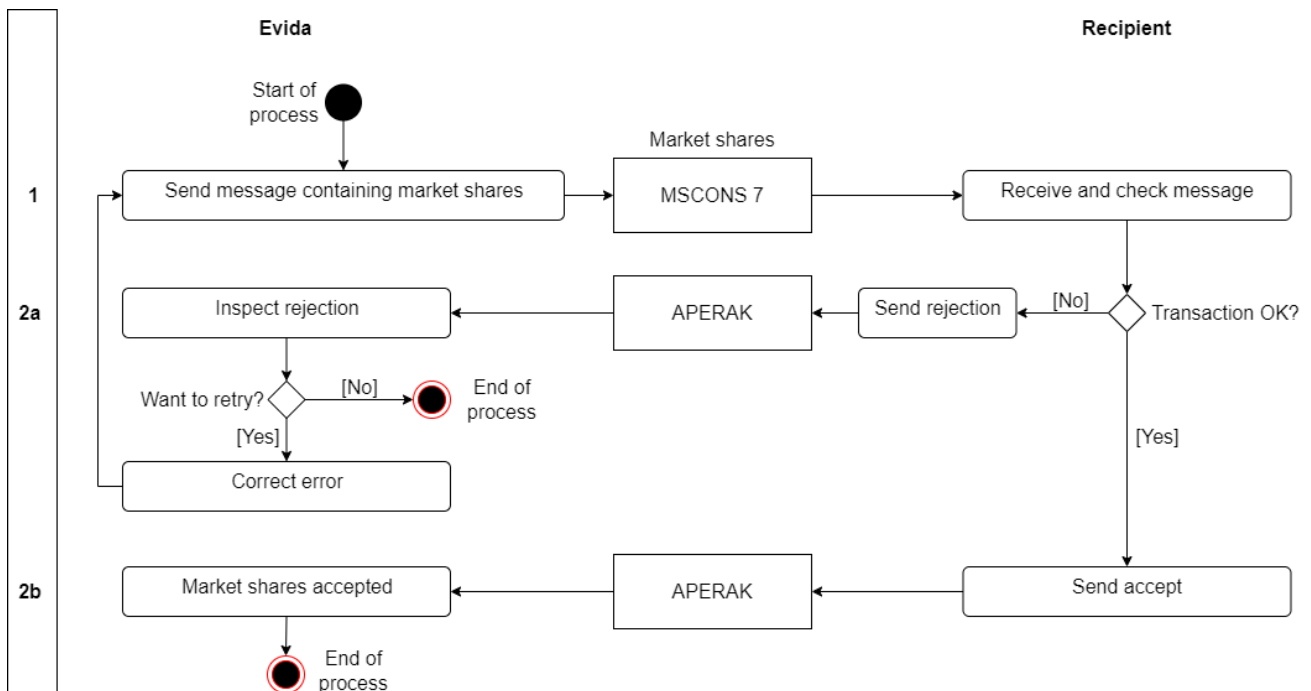

Figure 7: BT-009: Report reconciliation data (MSCONS 7)

Business Transaction, BT-009 is used by the *Evida* to send an EDI message containing the reconciliation data to a receiving party. The receiving party could be: a *Gas Supplier*, a *Shipper*, a *Transmission System Operator* or the *Elfor organisation*.

2.7.1. Initiation of the transaction

The transaction is initiated by a *MSCONS 7 (Process Data Report, Time Series)* message. The message can hold one or more time series. Before time series are sent the receiver must be informed of the *Serial ID* to be used for the time series and its relevant master data.

2.7.2. First dataflow: MSCONS 7

The message is sent with data as referred to in the dependency matrix. Please note that most dependencies are specified in the product code table. *MSCONS 7* has *message function "9 (Original)"* for all usage of this Business Transaction.

Receipt

On receipt of the message the validation is carried out in accordance with *EDI-communication (Regulation F)*.

Afterwards, each time series is verified in accordance with the business rules, which are documented in Table 26.

Validation	Error code
Time zone shall be equal to that specified in the master data for the <i>Serial ID</i>	42 (Error in content of a data element)
The <i>Metered time interval</i> shall be equal to the next calendar month	42 (Error in content of a data element)
The <i>Serial ID</i> and master data for it must be informed beforehand	42 (Error in content of a data element)
The <i>Product code</i> must be equal to that specified in the master data for the <i>Serial ID</i>	42 (Error in content of a data element)

The <i>Area 1</i> must be equal to that specified in the master data for the <i>Serial ID</i>	42 (Error in content of a data element)
The <i>Company 2</i> (if required) must be equal to that specified in the master data for the <i>Serial ID</i>	42 (Error in content of a data element)
The <i>Measure unit</i> must be equal to that specified in the master data for the <i>Serial ID</i>	42 (Error in content of a data element)
The <i>Quantity time intervals</i> must be within <i>Metered time interval</i>	44 (The value of a data element is out of range)
The <i>Quantity time intervals</i> must have the length specified in the master data for the <i>Serial ID</i>	42 (Error in content of a data element)
The precision (number of decimals) of the <i>Quantity</i> must be less or equal to what is specified in the master data for the <i>Serial ID</i>	42 (Error in content of a data element)

Table 26: Validation of first dataflow: MSCONS 7

2.7.3. Second dataflow: APERAK

If a time series fulfils all the conditions in Table 26, it must be approved. This is done by sending a positive *APERAK* with *message function* "34" (*Accepted with amendment*), the *error code* "100" (*The object is approved*) and "Godkendt/Approved" as *error description*. The transaction reference shall indicate the *Serial ID*.

In case of verification failure, the time series is rejected by a negative *APERAK* with *message function* "34" (*Accepted with amendment*) and the *error code* value indicated in the validation table. The name of the attribute that is the cause for failure must be stated in both Danish and English in the *error description*. The transaction reference shall indicate the *Serial ID*.

Receipt

On receipt, the *APERAK* is validated according to *EDI-communication (Regulation F)*.

Afterwards, the application is not allowed to reject the transactions in the *APERAK*.

2.7.4. MSCONS 7 - Dependency Matrix for Attributes

Attributes	
IG version	R
BT combined ID	R
Message date	R
Message function (9)	R
Message id	R
Message name	R
Message recipient	R
Message sender	R
Request for acknowledgement	R
Time zone	R
Metered time interval	R
Serial ID	R
Product code	R
Area 1	R
Company 2	D*
Measure unit	R
Quantity time interval	R
Quantity	R
Quantity status code	R

Table 27 BT-009: Dependency matrix for attributes: MSCONS 7

* Dependency specified in the product code list

R= Required, D= Dependent

2.7.5. APERAK - Dependency Matrix for Attributes

Attributes	Dependency
IG version	R
BT combined ID	
Message date	
Message function	
Message recipient	
Message sender	
Reference to message	
Application error code	
Error description	
Transaction reference	

Table 28: Dependency matrix for attributes: APERAK

R= Required

2.7.6. Unique Identification

BT ID	DK-BT-009
BT name	Reconciliation data transmission
BT version	5

BT combined ID	DK-BT-009-005
BPI	DK-TIS-SHA
EDI Messages:	
Message ID	MSCONS 7
Message name	Process Data Report, time series
Message IG version	3.1
DK IG version	3
Message ID	APERAK
Message name	Application error and acknowledgement message
Message IG version	3.1
DK IG version	3

2.7.7. Examples

MSCONS 7 (Reconciliation data transmission)

```

UNA:+. ? '
UNB+UNOC:3+5790000610976:14+5791111333334:14+031023:1233+A0310231233510++
DK-TIS-SHA+++DK'
UNH+127+MSCONS:D:96A:ZZ:E2DK03+DK-BT-009-005'
BGM+7+REF6262+9+AB'
DTM+137:200401151540:203'
DTM+163:200402010500:203'
DTM+164:200502010500:203'
DTM+ZZZ:0:805'
NAD+FR+5790000610976::9'
NAD+DO+5791111333334::9'
UNS+D'
NAD+XX'
LOC+90+579221122222312323::9'
LIN+1++3014:::DK'
MEA+AAZ++KWH'
QTY+31:125125.34'
DTM+324:200402010500200502010500:Z13'
NAD+XX'
LOC+90+579331122222312357::9'
LIN+1++3013:::DK'
MEA+AAZ++KWH'
QTY+31:125125125.34'
DTM+324:200402010500200502010500:Z13'
CNT+1:125250250.68'
UNT+21+127'
UNZ+1+A0310231233510'

```

2.8. BT-010 Request for Update of Master Data (UTILMD E10)

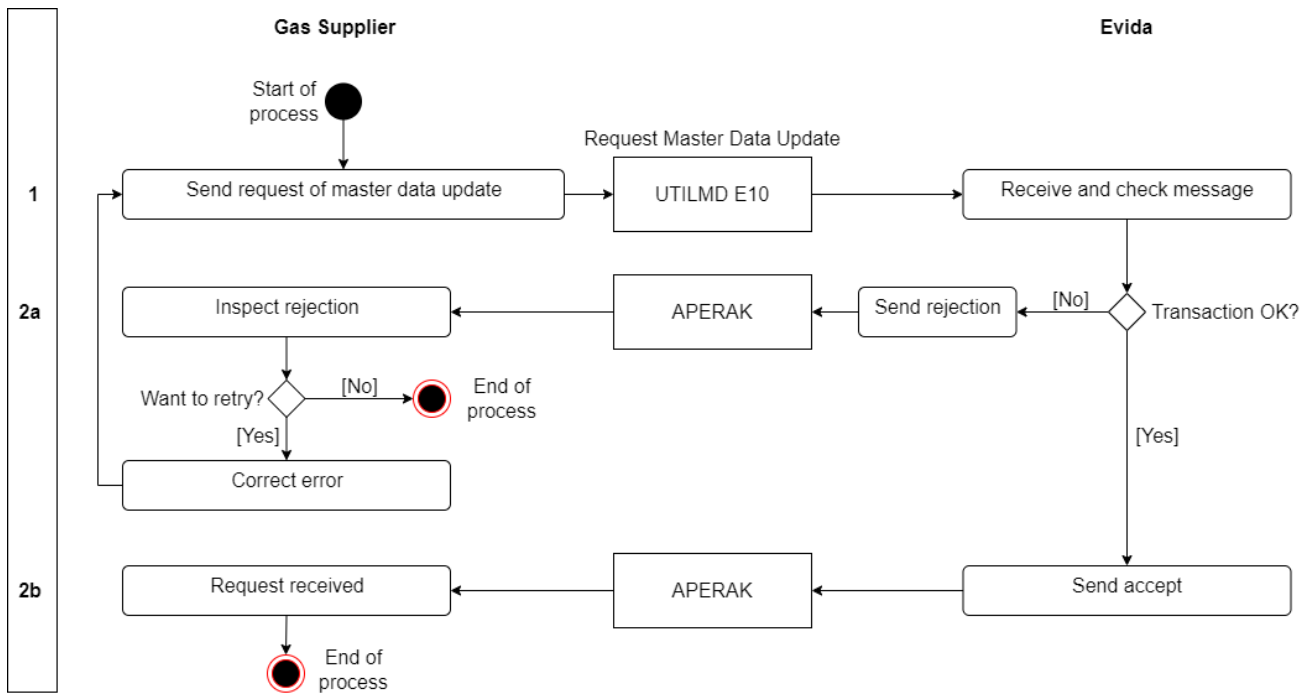

Figure 8: BT-010: Request for Update of Master Data (UTILMD E10)

Business Transaction BT-010 is used by the *Gas Supplier* to send an EDI message containing a suggestion for a master data update to *Evida*.

2.8.1. Initiation of the transaction

The transaction is initiated by a *UTILMD* message with a document name code *E10* (*Request of Master Data Update*). The message can hold one or more transactions with the same *Reason for Transaction (RFT)*. The value can be:

- Z16 Suggestion for change of master data

2.8.2. First dataflow: UTILMD E10

The message can be sent from the Gas Supplier to Evida and must adhere to the dependency matrix.

Receipt

On receipt of the message the validation is carried out in accordance with *EDI-communication (Regulation F)*.

Afterwards, each transaction is verified in accordance with the business rules, which are documented in Table 17.

RFT	Validation	Error code
Z16	The <i>Metering point</i> must be administrated by Evida	E10 (Installation address or metering point not identifiable)
Z16	The <i>Gas Supplier</i> must be approved (authorised) at <i>Validity Start Date</i> .	E16 (Unauthorised supplier)
Z16	The validation date must be received in accordance with the time limits	E17 (Requested switch date not within time limits)
Z16	The Metering Point has been discontinued on the requested date	Z12 (Discontinued Metering Point)

Table 29: BT-004: Validation of first dataflow: UTILMD E07

2.8.3. Second dataflow: APERAK

If a transaction fulfils all the conditions in Table 17, it must be approved. This is done by sending a positive *APERAK* with *message function "34" (Accepted with amendment)*, the *error code "100" (The object is approved)* and "Godkendt/Approved" as *error description*. The transaction reference shall indicate the *Transaction ID*.

In case of verification failure, the transaction is rejected by a negative *APERAK* with *message function "34" (Accepted with amendment)* and the *error code* value indicated in the validation table. The name of the attribute that is the cause for failure must be stated in both Danish and English in the *error description*. The transaction reference shall indicate the *Transaction ID*.

Receipt

On receipt of the message the validation is carried out in accordance with *EDI-communication (Regulation F)*.

Afterwards, the application is not allowed to reject the transactions.

2.8.4. UTILMD E10 - Dependency Matrix for Attributes

Attributes	RFT
	Z16
IG version	R
BT combined ID	
Market	
Message date	
Message function	
Message id	
Message name	
Message recipient	
Message sender	
Request for acknowledgement	
Time zone (UTC+0)	
Metering point id	
Reason for transaction	
Transaction id	
Contract start date	X
Validity start date	R
Gas Supplier	X
Estimated annual volume	
Consumer party name	R
Metering point address	X
Settlement method	
Next scheduled meter reading date	
Physical status for metering point	R
Consumer party contact address	

Table 30 BT-004: Dependency matrix for attributes: UTILMD E07

R= Required, D= Dependent, X= Not used

2.8.5. APERAK - Dependency Matrix for Attributes

Attributes	Dependency
IG version	R
BT combined ID	
Message date	
Message function	
Message recipient	
Message sender	
Reference to message	
Application error code	
Error description	
Transaction reference	

Table 31 BT-004: Dependency matrix for attributes: APERAK

R= Required

2.8.6. Unique Identification

BT ID	DK-BT-010
BT navn	Request for Master Data Update
BT version	5
BT combined ID	DK-BT-010-005
BPI	DK-CUS
EDI Messages used	
Message ID	UTILMD E10
Message name	Request for Master Data Update
Message IG version	5.0 B
DK IG version	3
Message ID	APERAK
Message name	Application error and acknowledgement message
Message IG version	2.4 B
DK IG version	3

2.8.7. Examples

UTILMD E10/Z16 (Suggestion for master data)

```

UNA:+. ? '
UNB+UNOC:3+5799999911118:14+5799999933318:14+031001:1415+UNIKT053++DK-
CUS+++DK '
UNH+1+UTILMD:D:02B:UN:E5DK03+DK-BT-010-005 '
BGM+E10::260+MES053+9+AB '
DTM+137:200310011215:203 '
DTM+735:?+0000:406 '
MKS+27+E01::260 '
NAD+MS+5799999911118::9 '
NAD+MR+5799999933318::9 '
IDE+24+TrID53 '
DTM+157:200301310500:203 '
STS+7++Z16::260 '
LOC+172+571515199988888819::9 '
NAD+DDQ+5799999933318::9 '
NAD+IT++++::714;67;12;St;2+Fredericia++7000+DK '
NAD+UD+12345678++John Jensen:Dorthe Jensen+Jensensvej:A:5:714;67;12;St;2+Fredericia++7000+DK '
UNT+15+1 '
UNZ+1+UNIKT053 '

```

2.9. BT-011 Meter Reading from Gas Supplier (UTILMD Z21)

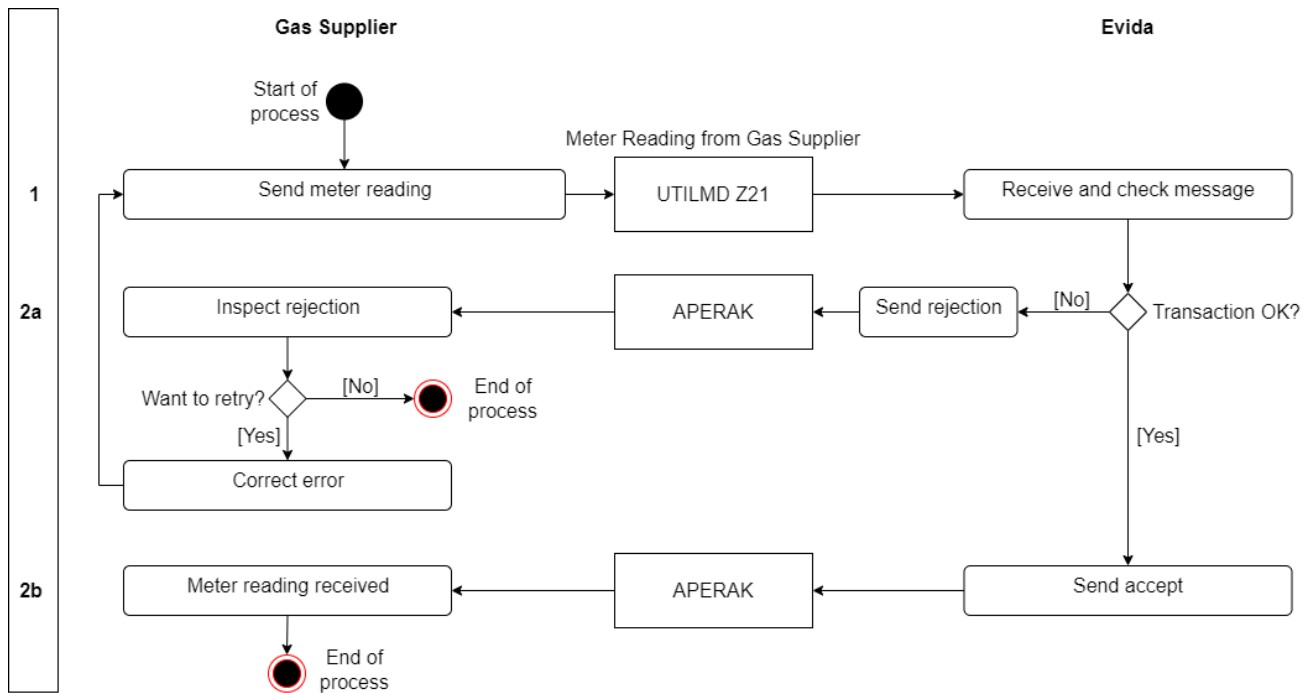

Figure 9: BT-011: Meter Reading from Gas Supplier (UTILMD Z21)

Business Transaction BT-011 is used by the *Gas Supplier* to send an EDI message containing a meter reading to *Evida*.

2.9.1. Initiation of the transaction

The transaction is initiated by a *UTILMD* message with a document name code *Z21* (*Meter Reading from Gas Supplier*). The message can hold one or more transactions with the same *Reason for Transaction (RFT)*. The value can be:

- E01 Move
- Z17 Secondary move in
- Z22 Meter Reading

2.9.2. First dataflow: UTILMD Z21

The message can be sent from the Gas Supplier to Evida and must adhere to the dependency matrix.

Receipt

On receipt of the message the validation is carried out in accordance with *EDI-communication (Regulation F)*.

Afterwards, each transaction is verified in accordance with the business rules, which are documented in Table 17.

RFT	Validation	Error code
E01 Z17 Z22	The <i>Metering point</i> must be administrated by Evida	E10 (Installation address or metering point not identifiable)
E01 Z17 Z22	The <i>Gas Supplier</i> must be approved (authorised) at <i>Validity Start Date</i> .	E16 (Unauthorised supplier)
E01 Z17 Z22	The validation date must be received in accordance with the time limits	E17 (Requested switch date not within time limits)
E01 Z17 Z22	The Metering Point has been discontinued on the requested date	Z12 (Discontinued Metering Point)
E01 Z17 Z22	The metering point is not the correct type	Z23 (Metering point is not correct type)

Table 32: BT-004: Validation of first dataflow: UTILMD E07

2.9.3. Second dataflow: APERAK

If a transaction fulfils all the conditions in Table 17, it must be approved. This is done by sending a positive *APERAK* with *message function "34" (Accepted with amendment)*, the *error code "100" (The object is approved)* and "*Godkendt/Approved*" as *error description*. The transaction reference shall indicate the *Transaction ID*.

In case of verification failure, the transaction is rejected by a negative *APERAK* with *message function "34" (Accepted with amendment)* and the *error code* value indicated in the validation table. The name of the attribute that is the cause for failure must be stated in both Danish and English in the *error description*. The transaction reference shall indicate the *Transaction ID*.

Receipt

On receipt of the message the validation is carried out in accordance with *EDI-communication (Regulation F)*.

Afterwards, the application is not allowed to reject the transactions.

2.9.4. UTILMD Z21 - Dependency Matrix for Attributes

Attributes	RFT
	All
IG version	R
BT combined ID	
Market	
Message date	
Message function	
Message id	
Message name	
Message recipient	
Message sender	
Request for acknowledgement	
Time zone (UTC+0)	
Metering point id	
Reason for transaction	
Transaction id	
Contract start date	X
Validity start date	R
Gas Supplier	X
Estimated annual volume	
Consumer party name	R
Metering point address	
Settlement method	X
Next scheduled meter reading date	
Physical status for metering point	
Consumer party contact address	
Meter Reading	R

Table 33 BT-004: Dependency matrix for attributes: UTILMD E07

R= Required, D= Dependent, X= Not used

2.9.5. APERAK - Dependency Matrix for Attributes

Attributes	Dependency
IG version	R
BT combined ID	
Message date	
Message function	
Message recipient	
Message sender	
Reference to message	
Application error code	
Error description	
Transaction reference	

Table 34 BT-004: Dependency matrix for attributes: APERAK

R= Required

2.9.6. Unique Identification

BT ID	DK-BT-011
BT navn	Meter Reading from Gas Supplier
BT version	5
BT combined ID	DK-BT-011-005
BPI	DK-CUS
EDI Messages used	
Message ID	UTILMD Z21
Message name	Request for Master Data Update
Message IG version	5.0 B (but own transaction)
DK IG version	3
Message ID	APERAK
Message name	Application error and acknowledgement message
Message IG version	2.4 B
DK IG version	3

2.9.7. Examples

UTILMD Z21/E01 (Meter reading, move)

```

UNA:+. ? '
UNB+UNOC:3+5799999911118:14+5799999933318:14+031001:1415+UNIKT054++DK-
CUS+++DK '
UNH+1+UTILMD:D:02B:UN:E5DK03+DK-BT-011-005 '
BGM+E10::260+MES054+9+AB '
DTM+137:200310011215:203 '
DTM+735:?+0000:406 '
MKS+27+E01::260 '
NAD+MS+5799999911118::9 '
NAD+MR+5799999933318::9 '
IDE+24+TrID54 '
DTM+157:200301310500:203 '
STS+7++E01::260 '
LOC+172+57151519998888819::9 '
SEQ++1 '
QTY+220:6400:MTQ '
NAD+IT++++:::714;67;12;st;2+Fredericia++7000+DK '
UNT+15+1 '
UNZ+1+UNIKT054 '

```